

## Table of Contents

<b>Abstract</b>	Page 03
<b>Introduction</b>	Page 03
<b>LED Lighting Systems Q &amp; A</b>	
<b>General Information</b>	
What is the difference between indication and illumination?	Page 03
What is an LED?	Page 04
What determines the color of an LED?	Page 04
What now makes LEDs suitable for illumination applications?	Page 04
How is white light made with LEDs?	Page 05
Which method for creating white light is best?	Page 07
Will LEDs achieve high light output?	Page 07
What is an LED lighting system?	Page 07
<b>Electrical Properties</b>	
What are the electrical characteristics of LEDs?	Page 08
Why is it important to control the current through an LED?	Page 08
What is an LED driver?	Page 09
Can LEDs be dimmed?	Page 09
Does dimming LEDs cause color shifts?	Page 09
Does dimming LEDs decrease their lamp life?	Page 10
<b>Thermal Properties</b>	
How are LEDs affected by heat?	Page 10
Why is heat sinking important for LEDs?	Page 11
What types of heat sinking materials are used in LED lighting systems?	Page 11
<b>Optical Properties</b>	
How much light do LEDs produce?	Page 12
Are LEDs available in different beam distributions?	Page 12
Are LEDs inherently directional light sources?	Page 12
Does higher luminous intensity mean higher light output?	Page 13
What is the life of LEDs?	Page 13
Do all LEDs have the same lumen maintenance characteristics?	Page 14
Are there color variations among LEDs?	Page 15
How large can color variations be for acceptable use?	Page 15
<b>Applications</b>	
How do the color rendering characteristics of LEDs compare to other light sources?	Page 16
How are LEDs packaged into systems for lighting applications?	Page 16

Where might LEDs be found in the future?

Page 17

For which applications are LEDs expected to be energy-efficient alternatives?

Page 18

### **Availability**

What are some LED devices that are available?

Page 18

What are some LED drivers that are available?

Page 19

What are some LED lighting systems that are available?

Page 19

### **Resources**

Page 20

### **Sponsors and Credits**

Page 21

### **Glossary**

Page 22

### **Legal Notices**

Page 23

## Abstract

This publication answers some commonly asked questions about lighting systems using light emitting diodes (LEDs). *Lighting Answers: LED Lighting Systems* helps practitioners understand the differences between LEDs and other conventional light sources, as well as some of their relevant performance characteristics. Key issues that are important in understanding the effective use of LEDs in lighting applications, including electrical performance, thermal performance, and optical performance are described. This publication should be useful to any practitioner who wants to use LED systems effectively in lighting applications.

## Introduction

Light emitting diodes (LEDs) were first developed in the 1960s, but only in the past decade have LEDs had sufficient intensity for use in more than a handful of lighting applications (Stringfellow and Craford 1997), and specifiers are confronted with an increasing number of lighting products that incorporate LEDs for certain applications. Primarily, these applications have taken advantage of the characteristics of LEDs that have made them most suitable for **indication**, not **illumination** (Bierman 1998).

### What is the difference between indication and illumination?

**Indication** refers to the use of a light source that is to be viewed directly as a self-luminous object, such as in signs, signals, and indicator lights on electronic equipment. Examples of successful LED indication applications include exit signs (Boyce 1994; Bierman 1995; Bierman and O'Rourke 1998) and traffic signals (Conway and Bullough 1999). **Illumination** refers to the use of a light source to view other objects by the light reflected from those objects, such as the general lighting found in most rooms, or task lighting found on many desks. Figure 1 shows a typical indicator LED and a typical illuminator LED.

**Figure 1. LED typically used for indication (left); LED typically used for illumination (right). Not to scale.**

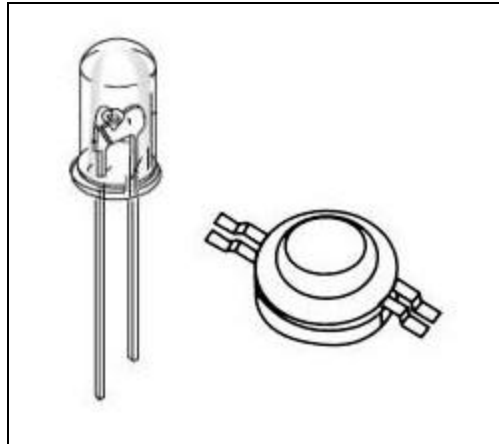

LEDs are quite effective and efficient for colored light applications. Unlike conventional signs and signals which use a nominally white light source and a colored glass or plastic filter or lens to create the sign or signal, colored LEDs require no filtering. The light absorbed by the filters in the conventional products is essentially wasted, and because of this waste, the luminous efficacy of LED signs and signals is often higher than those using conventional white light sources.

Recent technological advances (Nakamura 1999), such as the development of white light LEDs in the mid-1990s, have made LED illumination systems feasible for some applications, and a number of products are now available on the market. At present, typical indicator LEDs have light outputs on the order of one to several lumens, whereas LEDs for illumination produce on the order of tens to hundreds of lumens.

LED lighting systems continue to evolve rapidly (LRC 2003), and specific benchmarks for performance (e.g., luminous efficacy, light output) are being exceeded on a regular basis. Therefore this issue of *Lighting Answers*

focuses on issues relating to the technology of LEDs and issues that are likely to be important in specifying them for lighting applications, rather than statements about the suitability of specific LED packages for specific applications.

### What is an LED?

LEDs are **semiconductor** diodes, electronic devices that permit current to flow in only one direction. The diode is formed by bringing two slightly different materials together to form a PN junction (Figure 2). In a **PN junction**, the P side contains excess positive charge ("holes," indicating the absence of electrons) while the N side contains excess negative charge (electrons).

Figure 2. A simplified PN junction diagram.

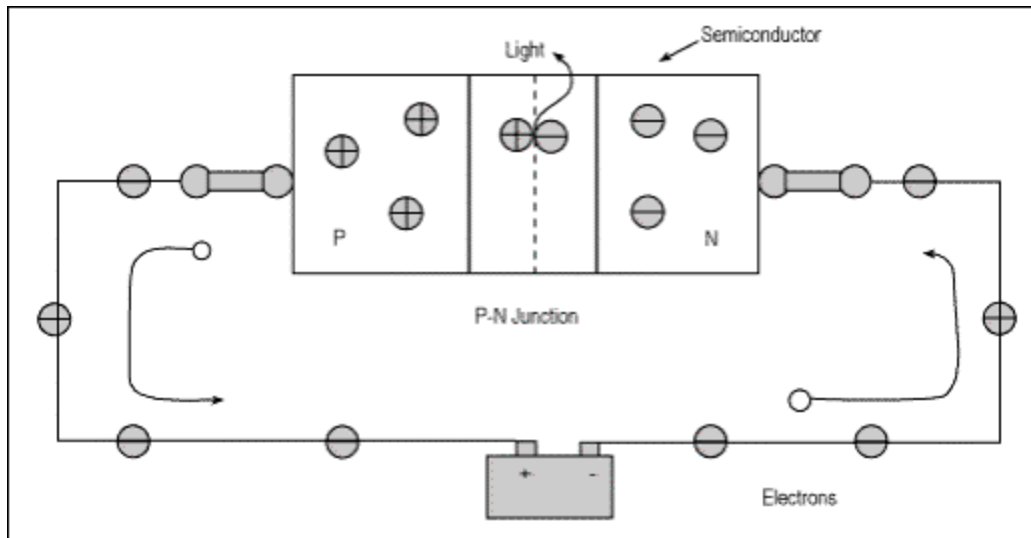

When a forward voltage is applied to the semiconducting element forming the PN junction (heretofore referred to as the junction), electrons move from the N area toward the P area and holes move toward the N area. Near the junction, the electrons and holes combine. As this occurs, energy is released in the form of light that is emitted by the LED.

### What determines the color of an LED?

The material used in the **semiconducting** element of an LED determines its color. The two main types of LEDs presently used for lighting systems are aluminum gallium indium phosphide (AlGaInP, sometimes rearranged as AlInGaP) alloys for red, orange and yellow LEDs; and indium gallium nitride (InGaN) alloys for green, blue and white LEDs. Slight changes in the composition of these alloys changes the color of the emitted light.

### What now makes LEDs suitable for illumination applications?

Early LEDs, such as those often used as indicator lights on electronic equipment, created very narrowband, but not quite **monochromatic** light ranging in color from yellow-green to red. But it was not until the development of AlGaInP and InGaN LEDs with much higher light output than the early indicator lamps, that useful quantities of light could be generated from LEDs. In addition, these materials allowed, for the first time, LEDs with peak wavelengths at any part of the visible spectrum to be made. White light can be made by mixing light from different parts of the spectrum (see also [How is white light made with LEDs?](#)).

Larger devices and packages have increased the overall light output of LEDs to levels that are useful for some lighting applications. In addition to increased size of the **semiconducting** elements, LED construction has also changed to make them more efficient. The crystals forming early LED junctions were grown on light-absorbing **substrate** materials. Using transparent substrates and optimizing the shape of the semiconducting element have increased the amount of light able to leave the device, as shown in Figure 3.

**Figure 3. Improved design of LEDs to increase efficiency.**

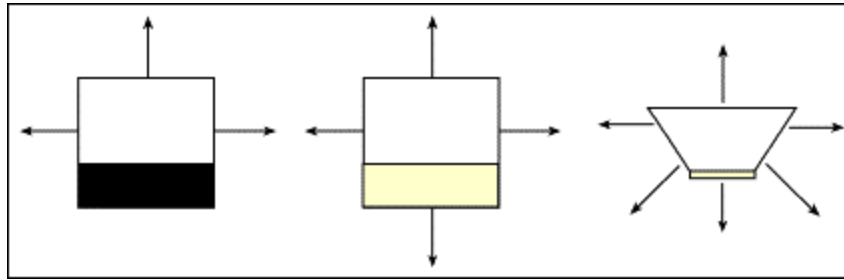

The substrates are shown as shaded areas. Early LEDs used light-absorbing substrates (left); later, transparent substrates were developed that permitted light to be emitted in additional directions (center); subsequent shaping of the semiconducting elements (right) has resulted in improved efficiency.

### **How is white light made with LEDs?**

Presently, there are two approaches to creating white light.

Mixed-color white light: One approach is to mix the light from several colored LEDs (Figure 4) to create a **spectral power distribution** that appears white. Similarly, so-called **tri-phosphor** fluorescent lamps use three phosphors, each emitting a relatively narrow spectrum of blue, green or red light upon receiving ultraviolet radiation from the mercury arc in the lamp tube. By locating red, green and blue LEDs adjacent to one another, and properly mixing the amount of their output (Zhao et al. 2002), the resulting light is white in appearance.

**Figure 4. Spectral power distributions of several types of LEDs.**

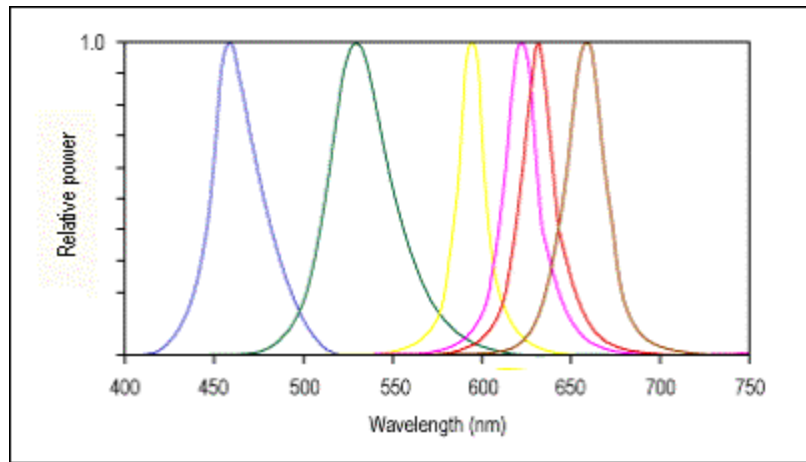

Phosphor-converted white light: Another approach to generating white light is by use of phosphors together with a short-wavelength LED. For example, when one phosphor material used in LEDs is illuminated by blue light, it emits yellow light having a fairly broad spectral power distribution. By incorporating the phosphor in the body of a blue LED with a peak wavelength around 450 to 470 nanometers, some of the blue light will be converted to yellow light by the phosphor. The remaining blue light, when mixed with the yellow light, results in white light. New phosphors are being developed to improve color rendering as shown in Figure 5.

**Figure 5. Spectral power distributions of early phosphor-based white LEDs (left), and white LEDs using more recently developed phosphors (right) with increased output between 600 and 650 nanometers.**

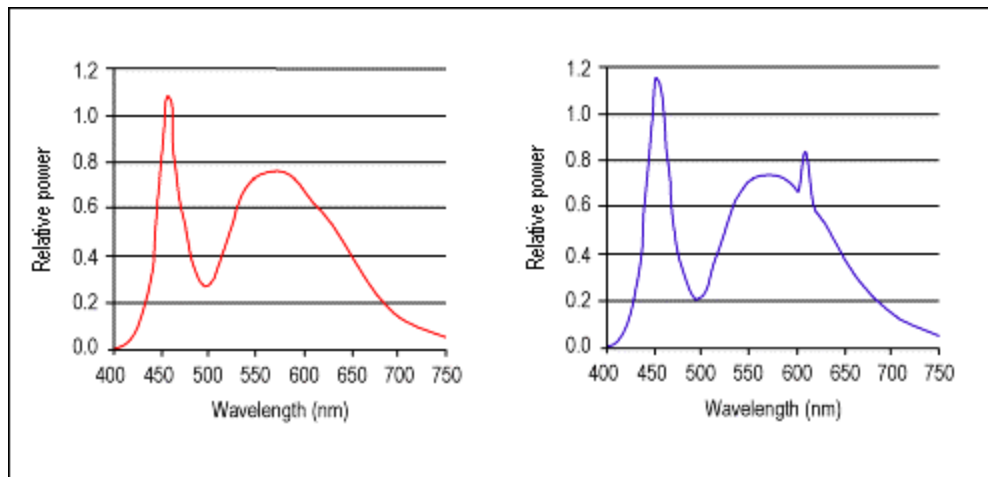

## Which method for creating white light is best?

The advantages and disadvantages of each method of creating white light are listed in Table 1.

**Table 1. Relative advantages and disadvantages of methods for creating white light with LEDs.**

Mixed-color white LEDs	Phosphor-converted white LEDs
<i>Advantages</i> <ul style="list-style-type: none"><li>• higher overall luminous efficacy</li><li>• good color rendering properties</li><li>• complete flexibility for achieving any desired color property</li></ul>	<i>Advantages</i> <ul style="list-style-type: none"><li>• results in a single, compact, white light source</li></ul>
<i>Disadvantages</i> <ul style="list-style-type: none"><li>• difficult to completely mix light</li><li>• difficult to maintain color stability over life and at different operating conditions, including dimming</li></ul>	<i>Disadvantages</i> <ul style="list-style-type: none"><li>• lower overall luminous efficacy</li><li>• uniform application of phosphor in manufacturing process is more difficult to control</li><li>• limited range of available color properties based on phosphor availability</li></ul>

## Will LEDs achieve high light output?

The first LEDs were quite small, with the **semiconductor** element only about 0.25 millimeters on edge. More recent designs have elements that are 1 millimeter on edge — significantly larger but still quite small. One of the limitations of large sizes is the problem of imperfections in the materials forming the semiconducting elements when they are deposited on much larger substrates; these imperfections greatly reduce efficiency. Thus, LEDs consisting of a single element will not likely exceed the light output of conventional light sources in the near future. However, LEDs with multiple elements packaged together into a single device are already available on the market; these devices are already approaching the lumen outputs found in some low-wattage incandescent lamps and future products will likely continue to offer greater light output.

## What is an LED lighting system?

As with other light source technologies, such as fluorescent and high intensity discharge (Rea 2000), lighting systems using LEDs (Figure 6) can be thought of as having a light source (typically, the individual LED sources), a ballast (for LEDs, often called a **driver**), and a luminaire (the surrounding materials for optical control of the emitted light and thermal control of the overall system). Unlike traditional lighting systems with few (typically, one to four) light sources, LED systems will likely contain arrays of many individual light sources in the near future. Figure 7 shows several arrays that are commercially available.

Figure 6. LED lighting system anatomy.

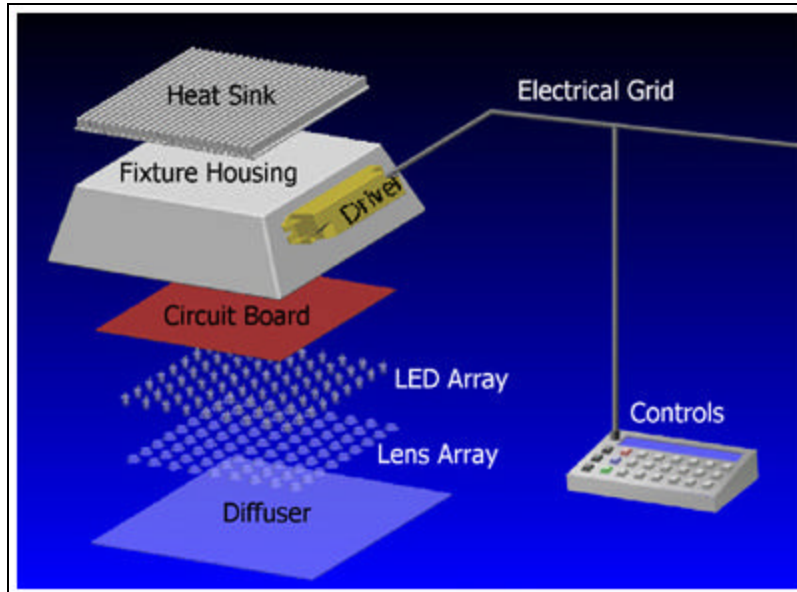
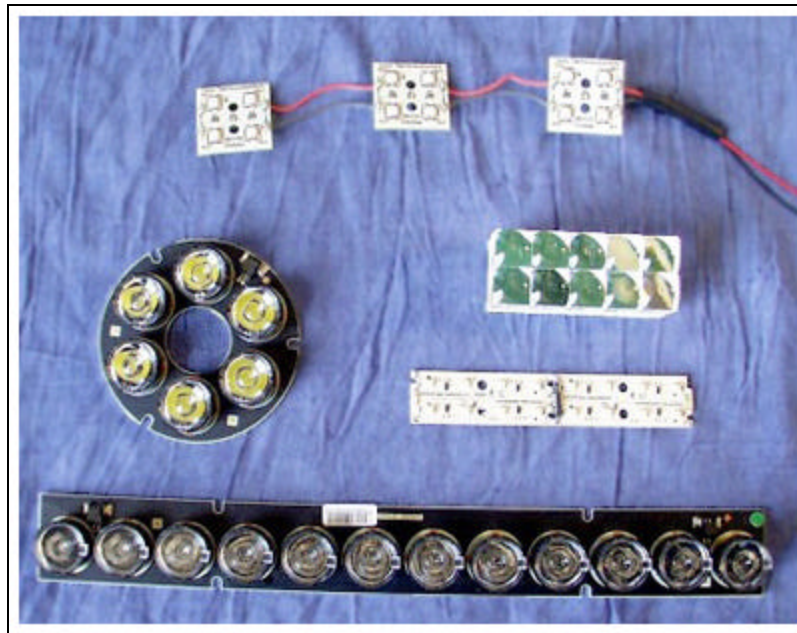

Figure 7. LED arrays.



### What are the electrical characteristics of LEDs?

Individual LEDs are low voltage devices. Single indicator LEDs require 2 to 4 volts of direct current, with current in the range from 1 to 50 milliamperes. An illumination-grade LED containing a single semiconducting element requires the same voltage, but operating currents are much higher, typically several hundred milliamperes. A device containing multiple elements connected in series will require higher voltage corresponding to the larger number of individual elements in the device.

LEDs require a specific electrical polarity (see [What is an LED?](#)). Applying voltage in reverse polarity can destroy them. Manufacturers provide specifications about the maximum reverse voltages acceptable for LED devices; 5 volts is a typical maximum rating.

### Why is it important to control the current through an LED?

A typical voltage-current relationship for an illumination-grade LED is shown in Figure 8. As seen in this figure, a

slight change in voltage can result in very large changes in current. Since the light output of an LED is proportional to its current, this can result in unacceptable variation in light output. If the resulting current exceeds limits recommended by the manufacturer, the long-term performance of the LED can be affected, resulting in shorter useful life.

**Figure 8. The relationship between forward voltage and current for illuminator LEDs.**

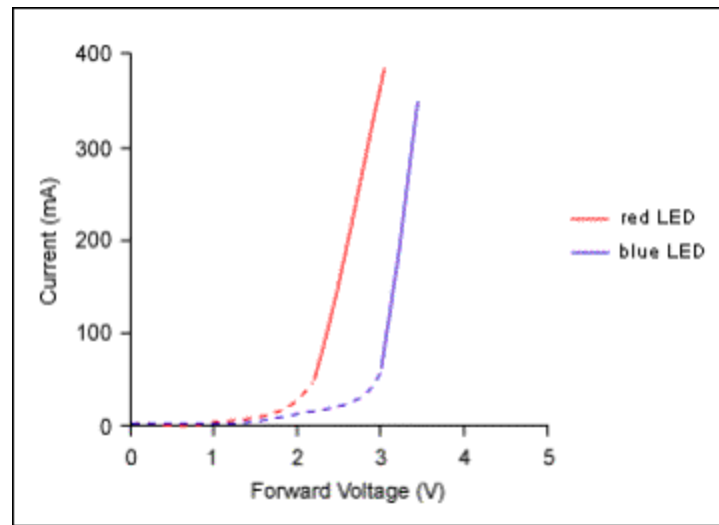

Data based on literature from LumiLeds

The solid line is for normal operating parameters; the dotted lines are extrapolated.

### What is an LED driver?

An LED **driver** performs a function similar to a ballast for discharge lamps. It controls the current flowing through the LED. Most LED drivers are designed to provide current to a specific device or array. Since LED packages and arrays are not presently standardized, it is very important that a driver is selected that is matched to the specific device or array to be illuminated.

### Can LEDs be dimmed?

The forward current is proportional to the light output of an LED over a large operating range, so dimming can be achieved with reductions in the forward current.

Because LEDs can be rapidly switched on and off with no harmful effects, dimming can also be accomplished using a method called **pulse width modulation**. By adjusting the relative duration of the pulse and the time between pulses, the apparent intensity of the LED can be dimmed. This must be done with high enough frequency (hundreds of thousands of modulations per second) that the LED appears to be continuously lighted, or else the rapid flickering will be distracting. This technique can be easily implemented electronically using direct digital control.

### Does dimming LEDs cause color shifts?

Changes in the current through an LED affect the **junction temperature** of the device, which can shift the **spectral power distributions** (see [How are LEDs affected by heat?](#)). Red and yellow AlGaInP LEDs have larger spectral shifts than blue, green and white InGaN LEDs (Stringfellow and Craford 1997), but none of these sources undergo a degree of color shift comparable to the color shift experienced when dimming an incandescent lamp. Differences among various colored LEDs could be problematic in arrays designed to mix colors to produce white light. Color appearance could shift unacceptably when dimming if the different color components change.

## Does dimming LEDs decrease their lamp life?

It has been observed that when some fluorescent lighting systems are frequently dimmed, they might exhibit reduced reliability and lamp life. This is not the case for LEDs. Life and light output degradation are determined largely by the **junction temperature**, with higher temperatures resulting in reduced life characteristics. Since dimming, either by reducing current or by **pulse width modulation**, results in lower overall junction temperatures, it will have no negative impact on LED life; it might even extend life. (See also [What is the life of LEDs?](#))

## How are LEDs affected by heat?

In general, the cooler the environment, the higher an LED's light output will be. Higher temperatures generally reduce light output. In warmer environments and at higher currents, the temperature of the **semiconducting element** increases. The light output of an LED for a constant current varies as a function of its **junction temperature**. Figure 9 shows the light output of several LEDs as a function of junction temperature. The temperature dependence is much less for InGaN LEDs (e.g., blue, green, white) than for AlGaInP LEDs (e.g., red and yellow).

**Figure 9. Relative light output of red, blue and phosphor-converted white LEDs as a function of the junction temperature.**

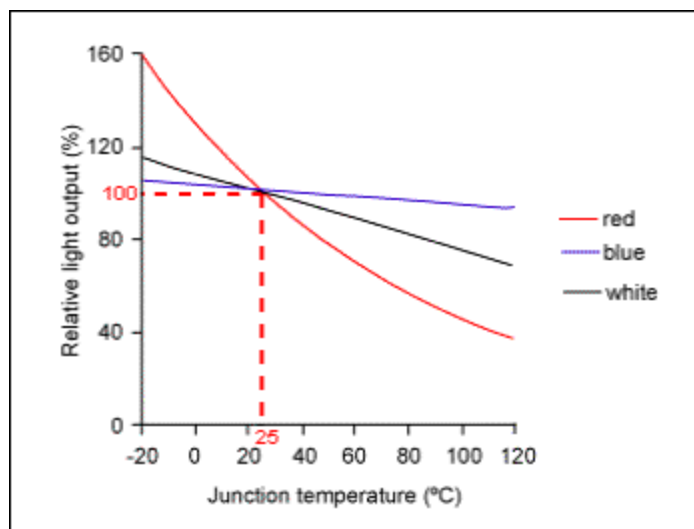

Data based on literature from LumiLeds

Data are normalized to 100% at a junction temperature of 25°C.

Some system manufacturers include a compensation circuit that adjusts the current through the LED to maintain constant light output for various ambient temperatures. This can result in overdriving LEDs in some systems during extended periods of high ambient temperature, potentially shortening their useful life.

Most LED manufacturers publish curves similar to those in Figure 9 for their products, and the precise relationships for various products will be different. It is important to note that many of these graphs show light output as a function of junction temperature and not ambient temperature. An LED operating in an ambient environment at normal room temperature (between 20°C and 25°C) and at manufacturer-recommended currents can have much higher junction temperatures, such as 60°C to 80°C. Junction temperature is a function of:

- ambient temperature
- current through the LED
- amount of **heat sinking** material in and around the LED

Generally, the lighting specifier does not need to be aware of these relationships; the maker of an LED lighting system should incorporate appropriate heat sinking and other compensatory mechanisms. The system

manufacturer should then provide a range of permissible operating temperatures within which acceptable operation will be expected.

Prolonged heat can significantly shorten the useful life of many LED systems. Higher ambient temperature leads to higher junction temperatures, which can increase the degradation rate of the LED junction element, possibly causing the light output of an LED to irreversibly decrease over the long term at a faster rate than at lower temperatures.

Controlling the temperature of an LED is, therefore, one of the most important aspects of optimum performance of LED systems.

### **Why is heat sinking important for LEDs?**

It is common to refer to LEDs as "cool" sources in terms of temperature. This is because the spectral output of LEDs for lighting does not contain infrared radiation, unlike incandescent lamps that produce a large amount of infrared (of course, some LEDs for manufacturing purposes are designed to produce infrared energy, but these are not considered in this publication). LEDs are also often considered "cool" because they generate light through a mechanism other than thermal excitation of a substance, such as the tungsten filament in an incandescent lamp. Although LED lighting systems do not produce significant amounts of radiated heat, LEDs still generate heat within the junction, which must be dissipated by **convection** and **conduction**. Extracting heat from the device using **heat sinks** and by operating LEDs in lower ambient temperatures enables higher light output and longer life of the device.

The need to ensure heat sinking with LED systems is also important to consider when these systems are installed in applications. There must be sufficient means to conduct the heat away from the system, or ventilation to cool heated surfaces by convection. Locating an LED lighting system in an insulated and relatively small space will likely result in rapidly increased **junction temperature** and suboptimal performance.

### **What types of heat sinking materials are used in LED lighting systems?**

Any material that can conduct heat away from the LED can serve as a **heat sink**. Most metals are excellent conductors of heat and therefore many LED manufacturers suggest that mounting materials containing metal frames, fasteners and connectors be used, and that the contact area between the LED and its mounting surface be maximized. It is also important to make a good thermal contact between the LED and its mounting surface.

Recent illumination-grade LEDs contain metal fins and wings to assist in heat sinking as well as large, flat areas suitable for attachment to heat sinks. Even larger heat sinking devices, such as those used in some computer systems, consisting of metal slugs shaped to maximize their surface area, can be incorporated into LED systems containing arrays of LEDs. These could even be integrated into the design of the system to increase attractiveness (Figure 10).

**Figure 10. Example of an attractive heat sink for LED lighting systems.**

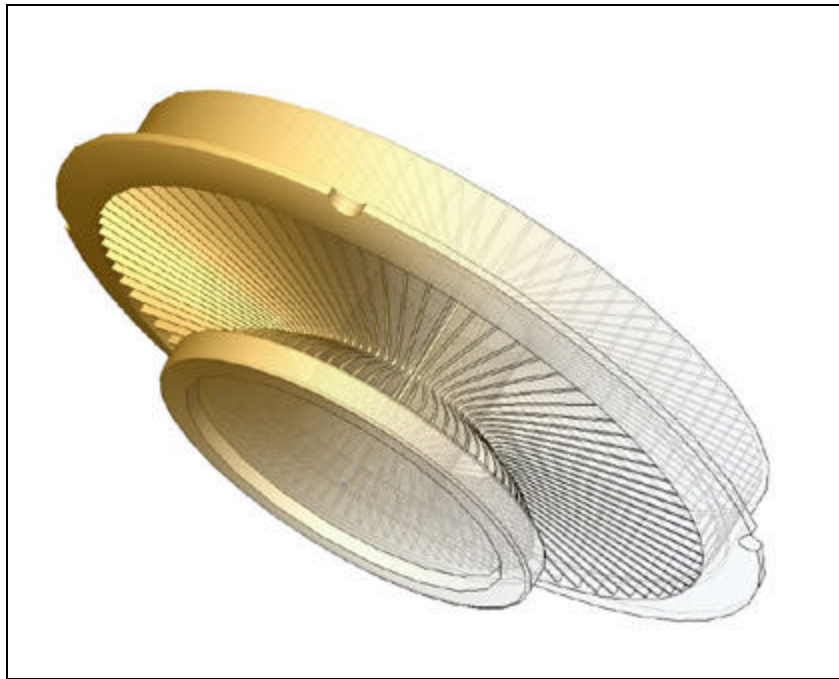

### **How much light do LEDs produce?**

Compared to most typical light sources used for lighting applications, LEDs still have relatively low light output, and therefore, will continue to be packaged into arrays and other configurations to be useful in such applications. At present, single white LED packages have reached nearly 100 lumens. Of course, the light output varies depending upon wavelength. Shown below are the ranges of light output for several different illumination-grade LED packages.

<b>Color</b>	<b>Light output (lm)</b>
White	18 -87
Blue	7 -30
Green	25 -120
Yellow	20 -69
Red	25 -55

### **Are LEDs available in different beam distributions?**

Yes. Some individual devices are available with near **cosine distribution**, others have some optical control built into them and spread light in a particular pattern to optimize performance for some applications. Additionally, LED systems can contain optical elements that will further adjust the resulting patterns of light from LEDs for particular applications.

### **Are LEDs inherently directional light sources?**

No. Since early LEDs were developed for indicator applications, the most efficient optical design for this purpose was to use the familiar epoxy capsule, which focuses light forward. However, there is nothing inherent in this degree of directionality for LED devices. An LED **semiconducting** element can potentially emit light in many directions, and many illumination-grade LEDs have fairly broad distribution (see [Are LEDs available in different beam distributions?](#)). Note that the opacity of **heat sinking** materials in some LED systems can limit the resulting distribution of light.

## Does higher luminous intensity mean higher light output?

Almost all indicator-type LEDs are rated by their manufacturers in terms of luminous intensity in candelas, rather than light output in lumens. Luminous intensity is a function of the angle from which an LED is seen, so this value should be considered carefully when used to characterize the light output of a particular LED. Two LEDs with the same luminous flux output can have very different peak luminous intensities, if they are designed to produce different **beam angles**. A narrower beam angle means a higher maximum luminous intensity for the same light output. LED packages are available in a range of beam angles from very narrow (near 6°) to quite wide (more than 100°); most illumination-grade LEDs are rated in terms of light output in lumens.

When using narrow-beam LEDs, it is important to note that small variations in mounting or aiming angle can have a large impact on the appearance of an array of these devices, if the array is designed to be viewed directly.

## What is the life of LEDs?

The lighting industry presently does not have a standard definition for LED lamp life (Narendren et al. 2001a). The lamp life definition for traditional light sources is the time at which 50% of the test samples have burned out (Rea 2000). LEDs generally do not fail by burning out but will slowly reduce in light output over time; as solid state devices they will continue to operate even after 100,000 hours, continuing to use electrical power even if they produce very little useful light. A comparison of **lumen maintenance** near the end of rated life for traditional light sources (e.g., incandescent, fluorescent, high intensity discharge) (Figure 11) shows that with the exception of metal halide lamps, these lamps usually have at least 80% of their initial light output by the time they have operated 10,000 hours. Furthermore, even when light level reductions occur over a few minutes, people tend not to notice them until the light level reaches 80% of the initial value (Kryszczuk and Boyce 2002). For these reasons, it may be appropriate to consider this criterion as a basis for "useful" life for LED sources used in general lighting.

**Figure 11. Lumen maintenance curves for different light sources out to 10,000 hours.**

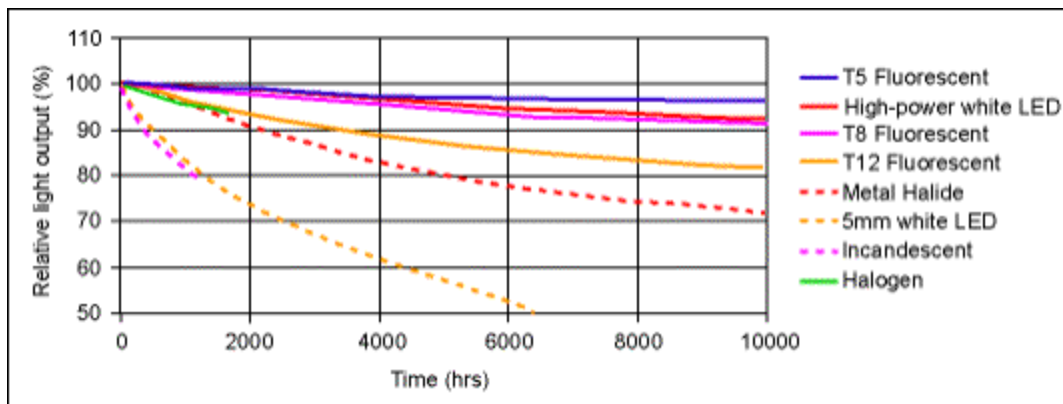

Indicator-type white LEDs that were on the market as recently as 2000 and 2001 reach 80% light output within 1000 to 2000 hours when operated at rated current in laboratory conditions (Figure 11) (Narendran et al. 2000a, 2001b). The high degradation rate in these LEDs is mainly due to yellowing of the clear epoxy material caused by high temperature in the **semiconducting** element. Newer, high-power, white LEDs have improved lumen maintenance, and therefore could have much longer lamp life (greater than 25,000 hours). Recent measurements by the Lighting Research Center have shown that these devices maintain their light output for significantly longer periods than indicator-type LEDs using earlier technology (Narendran and Deng 2002a). This is largely due to improved thermal management and **heat sinking** characteristics.

## Do all LEDs have the same lumen maintenance characteristics?

No; lumen maintenance depends on several factors:

- the LED package, as shown in [Figure 1](#)
- the operating conditions such as ambient temperature or current through the LED
- the LED color (different semiconductor materials will have different degradation properties; additionally, short-wavelength light will tend to cause more degradation in epoxy materials used to encapsulate the junction element; see Figure 12)

It is also important to note that the performance of a single LED in a system might not accurately represent the performance of the entire system. For example, LEDs near the center of an array might experience higher overall temperatures and therefore experience greater reductions in performance than LEDs near the edge of an array (Narendran and Bullough 2001).

Various colored LEDs have different rates of lumen maintenance. As an example, Figure 12 shows lumen maintenance of red, green, blue and white indicator-type LEDs.

**Figure 12. Lumen maintenance of several colors of indicator-type LEDs as a function of operating time.**

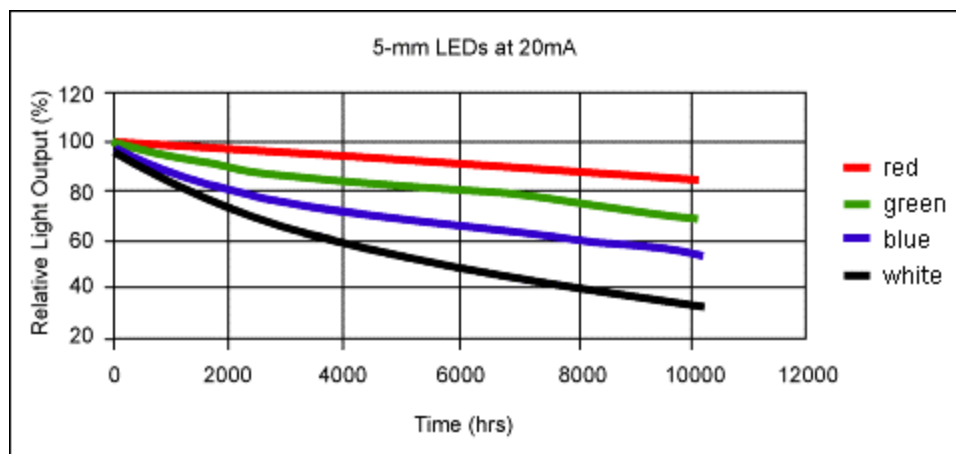

Illumination-grade LEDs have higher overall lumen maintenance but the relationships among the colors are similar.

The current through an LED is also a large determinant of its lumen maintenance characteristics. Operating LEDs at higher than rated currents accelerates the degradation mechanism by creating higher **junction temperatures** (Figure 13).

**Figure 13. Overdriving phosphor-based white indicator LEDs and the impact on lumen maintenance.**

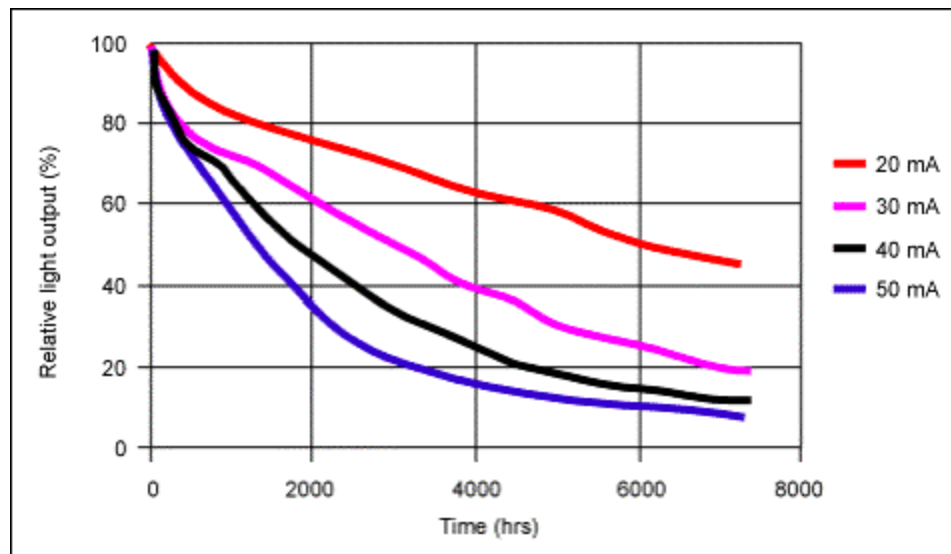

For some applications such as some decorative applications, lumen maintenance lower than 70% might be acceptable (Narendran and Bullough 2001). Until the industry develops consistent criteria for evaluating life for these types of light sources, the specifier or lighting system manufacturer must consult with the LED manufacturer to ensure that the sources will provide sufficient light output for the specific application.

### **Are there color variations among LEDs?**

There are generally small differences in color among LEDs when they are first manufactured, and then drifts in color as they are operated over the long term. With mixed-color systems to create white light, the initial color is probably more consistent, but without carefully designed compensation circuits to account for the different rates of lumen maintenance for the various colors used, the appearance of the light from a mixed-color array can drift noticeably from white. With phosphor-based white LED devices, small manufacturing differences in depositing the phosphor near the **semiconducting** element can alter the initial appearance of the resulting light; further, differences in the degradation rates of the phosphor and the emitter can also create variations in color through time.

Manufacturers work to **bin** LEDs to provide batches of products that will have similar initial appearance and lumen maintenance characteristics to maintain consistent appearance. Binning LEDs for small differences can increase their cost and the resulting cost of systems using them.

### **How large can color variations be for acceptable use?**

At present there are no standards for how large color variations can be for acceptability. Research studies for different applications provide some guidance for those applications, but the acceptable tolerances for some applications will be different from those for other applications. For example, if a lighted scene contains many different colors, such as a retail grocery display (Figure 14), the tolerance for color variations among different locations in the display would be greater than if the location to be lighted were a plain, light-colored wall (Narendran et al. 2003b).

**Figure 14. Retail grocery display.**



Small color variations in the illumination from one shelf to another in refrigerated display cases will be difficult to detect when the display contains colored packages as shown here.

### **How do the color rendering characteristics of LEDs compare to other light sources?**

Typical phosphor-based white LEDs have color rendering index (CRI) values comparable to discharge lamps (fluorescent and high intensity discharge) used in many lighting applications. Common belief is that high CRI means good color rendering properties. CRI is actually an index of how similar a light source makes colors appear in comparison to a reference source such as incandescent (which is why an incandescent lamp has a CRI near 100). For mixed-color LED systems, CRI is very sensitive to the wavelengths of the component colors; however, this sensitivity is not necessarily representative of one's preference for color appearance in an actual application. Recent studies have shown that mixed-color white LED systems with CRI in the 20s can result in higher color preference than systems with CRI in the 90s (Narendran and Deng 2002b). Knowing the limitations of CRI, international standard-setting bodies are working to explore newer metrics for better characterizing the color rendering properties of all light sources, including LEDs.

### **How are LEDs packaged into systems for lighting applications?**

The evolution of traffic signals using LEDs (Conway and Bullough 1999) provides a useful illustration for the development of lighting products and systems using this light source (Figure 15). When devices producing greater amounts of light become available, products use them, bypassing design iterations using lower light output LEDs. Future development of LED lighting systems will likely follow similar trends in development.

**Figure 15. Evolution of LED traffic signal products.**

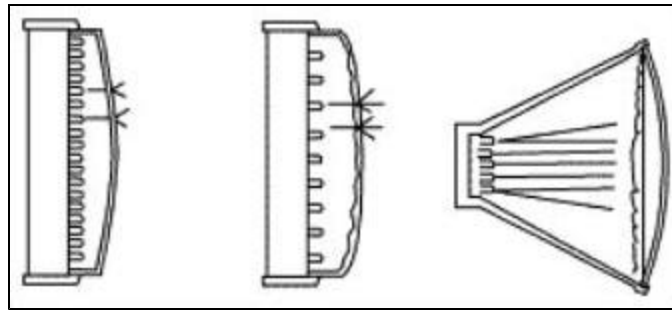

Early products used arrays of many LEDs (left); later products used fewer high-output LEDs with lenses to shape the resulting distribution (center); more recent devices use even fewer LEDs with yet higher output in combination with reflectors, diffusers and lenses (right).

### **Where might LEDs be found in the future?**

General lighting for interior applications such as offices and residences are considered by many to be the "Holy Grail" of lighting using LEDs. It might be ten years or longer before systems using LEDs are widely available for this type of general illumination, because of the relatively higher luminous efficacy of fluorescent systems and the low initial cost of incandescent systems. However, for applications where relatively low light levels are required or where saturated colors are desired, LEDs can be practical sources (Figures 16 and 17).

**Figure 16. LED MR-16 retrofit products.**



Courtesy, Color Kinetics

**Figure 17. LED outdoor lighting prototype**

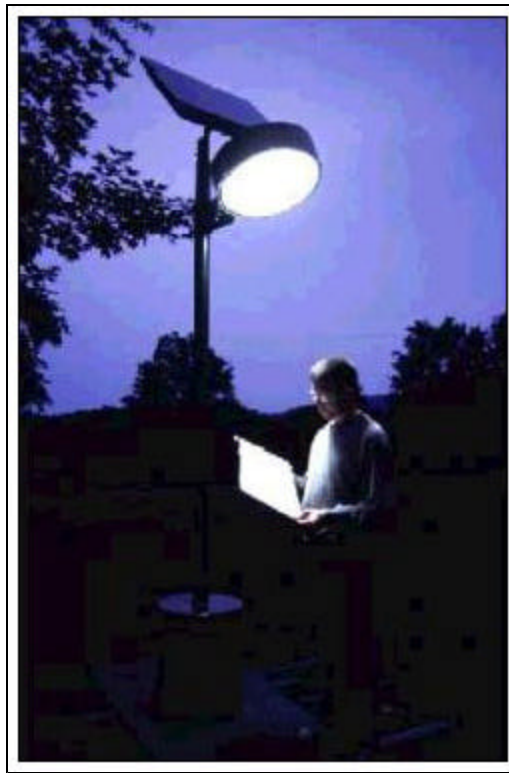

Source: Brandston et al. 2000

**For which applications are LEDs expected to be energy-efficient alternatives?**

When LEDs replace filtered white light sources or colored neon lamps in many signage, decorative and signaling applications, they will often be viable and efficient alternatives. In automotive displays, such as dashboards, the relatively long life of this source is beneficial because they help to prevent needs for replacement when lamps burn out.

At present, the efficiency of LED systems to produce white light has already begun to exceed that of incandescent lamps. **Illumination**-grade white LEDs range from 20 to 24 lumens/watt. Overall, properly designed LED lighting systems can be more efficient than incandescent, making them suitable for applications where low light levels are appropriate, such as decorative pathway lighting. Again, their life characteristics are important factors.

**What are some LED devices that are available?**

Manufacturer	Website	Examples
Cree, Inc.	<a href="http://www.cree.com">www.cree.com</a>	Xbright, Xbright Power Chip
Lumileds Lighting, LLC	<a href="http://www.lumileds.com">www.lumileds.com</a>	Luxeon Star, Emitter
Nichia Corporation	<a href="http://www.nichia.com">www.nichia.com</a>	High Power LED
Norlux	<a href="http://www.norluxcorp.com">www.norluxcorp.com</a>	Monochromatic Hex
Opto Technology, Inc.	<a href="http://www.optotech.com">www.optotech.com</a>	Shark Series
OSRAM Opto Semiconductors	<a href="http://www.osram-os.com">www.osram-os.com</a>	Power TOPLED

### What are some LED drivers that are available?

<b>Manufacturer</b>	<b>Website</b>	<b>Examples</b>
Advance Transformer	<a href="http://www.advancetransformer.com">www.advancetransformer.com</a>	Xitanium
Color Kinetics	<a href="http://www.colorkinetics.com">www.colorkinetics.com</a>	White LED Current Regulator
Maxim	<a href="http://www.maxim-ic.com">www.maxim-ic.com</a>	White LED Current Regulator
Microsemi	<a href="http://www.microsemi.com">www.microsemi.com</a>	High Efficiency LED Driver
OSRAM Opto Semiconductors	<a href="http://www.osram-os.com">www.osram-os.com</a>	Optotronics
Rohm	<a href="http://www.rohm.com">www.rohm.com</a>	White LED Driver
Toshiba*	<a href="http://www.marktechopto.com">www.marktechopto.com</a>	Constant Current LED Driver

\*distributed by Marktech Optoelectronics

### What are some LED lighting systems that are available?

<b>Manufacturer</b>	<b>Website</b>	<b>Examples</b>
Color Kinetics	<a href="http://www.colorkinetics.com">www.colorkinetics.com</a>	ColorBlast, iColor MR
GELcore	<a href="http://www.gelcore.com">www.gelcore.com</a>	Tetra
Lumileds Lighting, LLC	<a href="http://www.lumileds.com">www.lumileds.com</a>	Luxeon Flood, Line
OSRAM Opto Semiconductors	<a href="http://www.osram-os.com">www.osram-os.com</a>	EFFECTlight, LINEARlight

## Resources

### References

- Bierman, A. 1995. *Specifier Reports Supplements: Exit Signs*. Troy, NY: National Lighting Product Information Program, Lighting Research Center, Rensselaer Polytechnic Institute.
- Bierman, A. 1998. LEDs: From indicators to illumination? *Lighting Futures* 3(4): 1, 5.
- Bierman, A. and C. O'Rourke. 1998. *Specifier Reports Supplements 2: Exit Signs*. Troy, NY: National Lighting Product Information Program, Lighting Research Center, Rensselaer Polytechnic Institute.
- Boyce, P. R. 1994. *Specifier Reports: Exit Signs*. Troy, NY: National Lighting Product Information Program, Lighting Research Center, Rensselaer Polytechnic Institute.
- Brandston, H. M., A. J. Peterson, E. K. Simonson and P. R. Boyce. 2000. A white-LED post-top luminaire for rural applications. *Proceedings of the IESNA Annual Conference* (pp. 227-234), Washington, DC, July 31 -August 2. New York, NY: Illuminating Engineering Society of North America.
- Conway, K. M. and J. D. Bullough. 1999. Will LEDs transform traffic signals as they did exit signs? *Proceedings of the IESNA Annual Conference* (pp. 1-9), New Orleans, LA, August 9-11. New York, NY: Illuminating Engineering Society of North America.
- Kryszczuk, K. M. and P.R. Boyce. 2002. Detection of slow light level reduction. *Journal of the Illuminating Engineering Society* 31(2): 3-10.
- Lighting Research Center. *Solid-State Lighting*. Accessed on 8 April 2003 at <http://www.lrc.rpi.edu/programs/solidstate/>
- Nakamura, S. 1999. Present status of InGaN-based UV/blue/green LEDs and laser diodes. *Advances in Solid State Physics* 38: 1-14.
- Narendran, N., N. Maliyagoda, A. Bierman, R. Pysar and M. Overington. 2000a. Characterizing white LEDs for general illumination applications. *SPIE Proceedings* 3938: 240-248.
- Narendran, N., S. Vasconez, P. R. Boyce and N. H. Eklund. 2000b. Just perceivable color differences between similar light sources in display lighting applications. *Journal of the Illuminating Engineering Society* 29(2): 68-77.
- Narendran, N. and J. D. Bullough. 2001. Light emitting diodes as light sources. *Proceedings of the 9th International Symposium on the Science and Technology of Light Sources* (pp. 329-336), Ithaca, NY, August 12-16. Ithaca, NY: Cornell University Press.
- Narendran, N., J. D. Bullough, N. Maliyagoda and A. Bierman. 2001a. What is useful life for white light LEDs? *Journal of the Illuminating Engineering Society* 30(1): 57-67.
- Narendran, N., N. Maliyagoda, L. Deng and R. Pysar. 2001b. Characterizing LEDs for general illumination applications: Mixed-color and phosphor-based white sources. *SPIE Proceedings* 4445: 137-147.
- Narendran, N. and L. Deng. 2002a. Performance characteristics of light emitting diodes. *Proceedings of the IESNA Annual Conference* (pp. 157-164), Salt Lake City, UT, August 4-7. New York, NY: Illuminating Engineering Society of North America.
- Narendran, N. and L. Deng. 2002b. Color rendering properties of LED light sources. *SPIE Proceedings* 4776: 61 - 67.

Rea, M. S. (ed.). 2000. *IESNA Lighting Handbook: Reference and Application* (9th ed.). New York, NY: Illuminating Engineering Society of North America.

Stringfellow, G. B. and M. G. Craford (eds.). 1997. *High Brightness Light Emitting Diodes*. San Diego, CA: Academic Press.

Zhao, F., N. Narendran and J. F. Van Derlofske. 2002. Optical elements for mixing colored LEDs to create white light. *SPIE Proceedings 4776*: 207-214.

## Sponsors

California Energy Commission  
Iowa Energy Center  
Lighting Research Center  
New York State Energy Research and Development Authority  
Northwest Energy Efficiency Alliance  
U.S. Department of Energy  
U.S. Environmental Protection Agency  
Wisconsin Focus on Energy

## Acknowledgements

NLPIP thanks Stephen Johnson of the Lawrence Berkeley National Laboratory and N. Narendran and Andrew Bierman of the Lighting Research Center for providing technical review of this publication. Other Lighting Research Center personnel who provided technical contributions include Julia Ceriotti, Lei Deng, Russ Leslie, Lenda Lyman, and Ramesh Raghavan.

## Credits

### **Lighting Answers: Light Emitting Diode Lighting Systems Volume 7, Issue 3**

**May 2003**

Authors:	John D. Bullough
Program Director:	Conan O'Rourke
Editor:	Dennis Guyon
Designer/Graphics Developer:	James Gross Julie Bailey Jonas Concepcion
Technical Developers:	Rick Hadley Joann Coffey Robert Wolsey

## Glossary

Sources of term definitions: National Lighting Product Information Program (NLPIP), Lighting Research Center's Lighting Education Online, the IEEE Standard Dictionary of Electrical and Electronics Terms (IEEE Std 100-1996).

<b>Beam angle</b>	The angle at which luminous intensity is 50 percent of the maximum intensity.
<b>Bin</b>	To sort or classify light sources (such as light emitting diodes) into groups according to their luminous intensity or color appearance.
<b>Conduction</b>	The process of removing heat from an object via physical contact with other objects or materials, usually metals.
<b>Convection</b>	The process of removing heat from an object through the surrounding air.
<b>Cosine distribution</b>	A property of a light source such that its luminous intensity in a particular direction is proportional to the cosine of the angle from the normal to the source.
<b>Driver</b>	For light emitting diodes, a device that regulates the voltage and current powering the source.
<b>Heat Sinking</b>	Adding a material, usually metal, adjacent to an object in order to cool it through conduction.
<b>Illumination</b>	The process of using light to see objects at a particular location.
<b>Indication</b>	The process of using a light source as something to be seen as in signaling.
<b>Junction temperature</b>	For light emitting diodes, the temperature of the light-emitting portion of the device (see PN junction), which is inversely correlated with its light output.
<b>Lumen maintenance</b>	The lumens produced by a light source at any given time during its operating life as a percentage of its lumens at the beginning of life.
<b>Monochromatic</b>	For light, consisting of a single wavelength and having a very saturated color.
<b>PN junction</b>	For light emitting diodes, the portion of the device where positive and negative charges combine to produce light.
<b>Pulse width modulation</b>	Operating a light source by very rapidly (faster than can be detected visually) switching it on and off; the frequency and the duty cycle (percentage of time the source is switched on) are important parameters in the modulation.
<b>Semiconductor</b>	A material whose electrical conductivity is between that of a conductor and an insulator; the conductivity of most semiconductors is temperature dependent.
<b>Spectral power distribution</b>	A representation of the radiant power emitted by a light source as a function of wavelength.
<b>Substrate</b>	For light emitting diodes, the material on which the devices are constructed.
<b>Tri-phosphor</b>	A mixture of three phosphors to convert ultraviolet radiation to visible light in fluorescent lamps; each of the phosphors emits light that is blue, green or red in appearance with the combination producing white light.

## Legal Notices

*Lighting Answers* is a serial publication that complements the National Lighting Product Information Program's (NLPIP's) other serial, *Specifier Reports*. Each issue of *Lighting Answers* presents information in one of three formats: educational information about a specific topic of concern to lighting professionals, a summary of available information about a particular technology in an educational format with no testing, or information about a new or special technology on which NLPIP has performed some limited testing.

It is against the law to inaccurately present information extracted from *Lighting Answers* for product publicity purposes. Information in these reports may not be reproduced without permission of Rensselaer Polytechnic Institute.

---

[Contact Us](#)

©1995 -2003 Rensselaer Polytechnic Institute, Troy, NY 12180 USA - All Rights Reserved