

5.17 Swimming (Water Sports)

Swimming is a multi-directional ground level sport. It is a popular recreational activity as well as a competitive sport. Lighting design criteria are similar for both indoor and outdoor swimming pools. This section addresses both facilities with the emphasis placed on commercial, public, and institutional swimming pools. However, the illumination criteria is also applicable to private and recreational pools.

Swimming pools come in a wide variety of shapes and sizes and may be used day or night. However, competitive events occurring after dark are generally held at indoor facilities.

5.17.1 Illuminance Criteria (Pool). Swimming pool illuminance levels must serve the needs of swimmers, divers, life guards, instructors, and spectators. Particular attention must be paid to water characteristics and above-pool lighting:

- **Water Characteristics** - Water is a good transmitter and diffuser of light. However, the surface of water also acts as a reflector of incident light. The degree of reflection depends on the angle of incidence. Moreover, swimming action causes surface turbulence which produces scattered reflections. In practice, at any one moment, a major part of the water surface is not disturbed by more than 20 degrees from the horizontal.

As the light strikes the water at shallower angles, the reflected component increases until virtually no light penetrates the water surface. This reflection of light causes veiling reflections, making it difficult to see into the water to observe swimmers and divers. It is, therefore, necessary to control reflections from luminaires or daylight through windows on the water surface to ensure a good penetration of light into the water (see **Figure 8**).

Figure 44a and **Figure 44b** illustrate the reflection characteristics of light on a still water surface. As a general rule, it is desirable to locate all overhead light sources so the angle of incidence of the main light beam is less than 50 degrees from vertical. **Figure 44c** illustrates the reflecting and penetration property of light in still water.

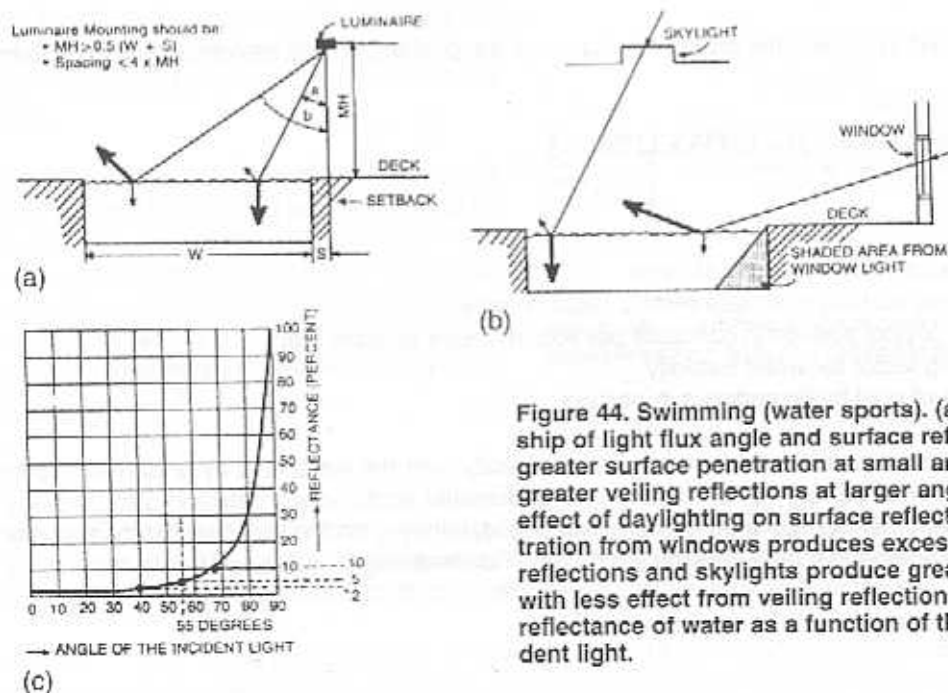

Figure 44. Swimming (water sports). (a) The relationship of light flux angle and surface reflection, i.e., greater surface penetration at small angle a , and greater veiling reflections at larger angle b . (b) The effect of daylighting on surface reflection: light penetration from windows produces excessive veiling reflections and skylights produce greater penetration with less effect from veiling reflections. (c) The reflectance of water as a function of the angle of incident light.

- **Above-Pool Lighting** - Light from above is required to illuminate pool deck areas, diving platforms, sport action occurring above the water surface (e.g., water polo), and to provide light penetration into the water basin.

Recommended illuminance levels are:

Class I - Horizontal illuminance:

Indoor - 750 lux (75 fc) Pool; 500 lux (50 fc) Deck Area
CV = 0.13 or less. ($E_{max}/E_{min} = 1.7:1$ or less)

Class II - Horizontal illuminance:

Indoor - 500 lux (50 fc) Pool; 200 lux (20 fc) Deck Area
Outdoor - 300 lux (30 fc) Pool; 200 lux (20 fc) Deck Area
CV = 0.21 or less. ($E_{max}/E_{min} = 2.5:1$ or less)

Class III - Horizontal illuminance:

Indoor - 300 lux (30 fc) Pool; 100 lux (10 fc) Deck Area
Outdoor - 300 lux (30 fc) Pool; 100 lux (10 fc) Deck Area
CV = 0.25 or less. ($E_{max}/E_{min} = 3:1$ or less)

Class IV - Horizontal illuminance:

Indoor - 300 lux (30 fc) Pool; 100 lux (10 fc) Deck Area
Outdoor - 100 lux (10 fc) Pool; 100 lux (10 fc) Deck Area
CV = 0.30 or less. ($E_{max}/E_{min} = 4:1$ or less)

Illuminance readings should be taken at water level.

5.17.2 Illuminance Criteria (Pool Basin). For improved safety and observation of swimmers in water, illuminances within the pool basin should exceed the luminance of reflected light from the water surface. Underwater luminaires are used to minimize veiling reflections on the surface of the water and enhance visibility for swimmers in the water. For maximum effectiveness, pool basin finishes below the water line preferably should be white or a color with a reflectance of not less than 50 percent.

The lumens required to provide the proper luminance of the pool basin may be computed by the following empirical formula:

$$\Phi = (100 \times A \times \pi \times L) / (0.8 \times \rho) = (393A \times L) / \rho$$

where:

- Φ = total luminous flux required in lumens
- A = area of water surface in square meters (square feet)
- L = luminance of pool surface in candelas per square meter (square foot)
- 0.8 = multiplying factor for water turbidity
- ρ = reflectance of pool basin surfaces in percent

Underwater illumination is produced from luminaires directly over the water and by underwater luminaires. As a general rule, unit power density (UPD) required for underwater lights varies between 5 to 30 watts per square meter (0.5 to 3 watts per square foot) of water surface depending on the class of facility and efficacy of light sources. The recommended minimum luminance from underwater lights alone is as follows.

Recommended luminances of the pool surface are:

Class I

Indoor - 376 candelas per square meter (35 candelas per square foot)

Class II

Indoor - 269 candelas per square meter (25 candelas per square foot)
Outdoor - 161 candelas per square meter (15 candelas per square foot)

Class III

Indoor - 161 candelas per square meter (15 candelas per square foot)

Outdoor – 108 candelas per square meter (10 candelas per square foot)

Class IV

Indoor – 161 candelas per square meter (15 candelas per square foot)

Outdoor – 54 candelas per square meter (5 candelas per square foot)

5.17.3 Design Considerations. Good lighting for swimming pools addresses three factors:

- *Luminaire Location* - Luminaires should be placed at locations that permit an adequate portion of the incident light to penetrate the water and not be reflected into the eyes of observers. Luminaires located near the pool edges are easy to maintain and can still provide good light penetration (see **Figure 44** and **Figure 45** in color insert). Luminaires should not be placed inside a 20-degree cone extending above the diving platform.
- *Daylight* - Daylight presents problems in terms of glare and reflection control (see **Figure 8d**). Daylight admitted from directly above the pool is desirable. But light from windows along the sides or ends of the pool can cause excess glare. The total intensity of the viewed scene (including reflections on the water) should be less than the illuminance in the pool basins. The illuminance from skylights can be calculated using any of the generally accepted algorithms. The skylights should be diffuse with splayed matte finished wells to prevent shafts of direct sunlight from entering the pool area.
- *Underwater Luminaires* - There are two types of underwater lighting; dry and wet niche mounting. For wet niches, special watertight luminaires are recessed into the pool walls. For dry niches, the luminaires are placed behind watertight portholes or windows. Wet niche designs, if defective, can produce electric shock. Thus the hardware, wiring installation, and ground fault detection methods used must strictly conform to the *National Electric Code*.¹⁰

Underwater lights should be placed about 0.61 to 0.91 meters (2.0 to 3.0 feet) below the water surface on the long sides of the pool with another row of luminaires at the 2.4- to 3.0-meter (8.0- to 10.0-foot) level for deep pools. Aiming should be approximately ten degrees above the horizontal so that light from the underwater luminaires reflects off the water surface and back into the pool.

Underwater luminaires should not face swimmers competing in parallel lanes. If the pool is too wide for luminaires with the recommended spacing on the long sides of the pool to provide proper coverage, narrow beam distribution and closer luminaire spacing should be considered. Correct mounting and spacing of typical underwater luminaires is shown in **Figure 46**.

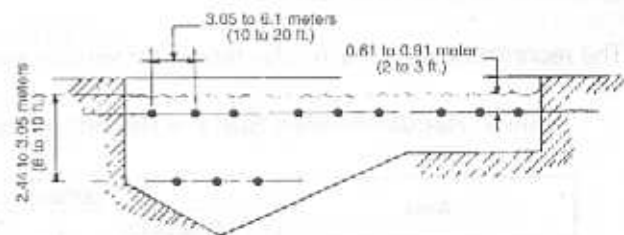

Figure 46. Mounting and spacing of underwater luminaires in a typical swimming pool.

5.18 Tennis

Tennis is a fast, multi-directional aerial sport. The tennis ball may approach the players at extremely high speed. Thus, while illuminance quantity and quality are most critical; illuminance uniformity, direct glare, and reflected glare come in a close second. Other important factors to consider when designing illumination for tennis facilities are:

- *Playing Areas* – The boundary line of a doubles tennis court is 10.97 meters (36 feet) wide by 23.78 meters (78 feet) long with a *court boundary area* of 260.9 square meters (2808 square feet). However, the *overall court area* of a tennis court is considerably larger than the court boundary area because the ball must be played far beyond the court boundaries. Normally, the overall court area of a single tennis court is 18.3 by 36.6 meters (60 by 120 feet) with an area of 669 square meters (7200 square feet). For Class I and II facilities, the overall court area may be as much as to 24.4 by 45.7 meters (80 by 150 feet) with an area of 1,115 square meters (12,000 square feet). For illumination design purposes, the overall court surface may be subdivided into two distinct areas: