

- 1 The Light Factory
- 2-3 Light defines space
 - Designing vertical illuminance
- 4-5 The basics
- 6-7 Internal areas
- 8-9 External areas
- 10-11 Internal and external areas – seen holistically
- 12-13 Colour and scenography
 - Lighting tools
- 14-15 Internal areas: wallwashers for track and light structures
- 16-17 Internal areas: recessed luminaires
- 18-19 External areas: floodlights and wallwashers
 - Design and planning in practice
- 20-23 Luminaire selection and arrangement
 - Experience light – globally
- 24-25 ERCO showrooms and offices
 - Lighting preview
- 26-27 Virtual luminaires and simulation
- 28-29 ERCO addresses



ERCO head office,
Lüdenscheid



First and foremost, ERCO sells light and not luminaires. This approach, which places the immaterial "software" of light above the luminaire hardware, has characterised our work for many years: that's why we call ourselves ERCO, the Light Factory. Light interprets space and helps us to perceive and experience its atmosphere. In this sense, we understand light as the "fourth dimension" of architecture.

Making good architecture even better by setting it in the right light, is where we see our cultural contribution and the purpose of our activity. Today ERCO illuminates museums, universities, window displays, churches, airports, hotels, retail chains, trade fair stands, administrative buildings, private houses and much more. Regardless of whether the architectural concept puts functionality or image to the fore, the goal is always to find a solution that does justice to the specific usage and architectural features of each individual project.

ERCO's indoor luminaires, outdoor luminaires and lighting control systems form a comprehensive programme of lighting tools for integrated, holistic lighting solutions in architecture. The luminaire is a lighting instrument, a lighting tool for a specific purpose.

This all leads to the conclusion that the illumination of walls and other vertical surfaces in architecture also requires dedicated instruments. The aesthetic and technical aspects of this form of lighting are the theme of this brochure.

Light defines space

Le Corbusier defined architecture as "the masterly, correct and magnificent interplay of masses brought together in light". His skill in the use of space and volume was consummate – but he would envy modern designers the options they have today for shaping and forming light itself as a medium.

With light, spaces can be defined and re-interpreted time and time again. Looking at walls and other surfaces, it becomes clear that these are decisive for the appreciation of architectural form: illuminated walls allow us to perceive the form and dimensions of a space; they make the entire space seem bright. A wall which is evenly illuminated gives an impression of being almost intangible. Objects such as photos, posters or paintings can be optimally viewed.

The lighting tools for this type of lighting are wallwashers. ERCO has been developing and perfecting these specialised luminaires for decades. The result is a range of instruments for the illumination of vertical surfaces which is hard to equal in terms of range and variety. Wallwashing is one of the most demanding types of lighting in terms of design and technology. The possibilities that this form of light offers design, the tools suitable for specific purposes and how they are best used – these questions and others will be dealt with on the following pages.

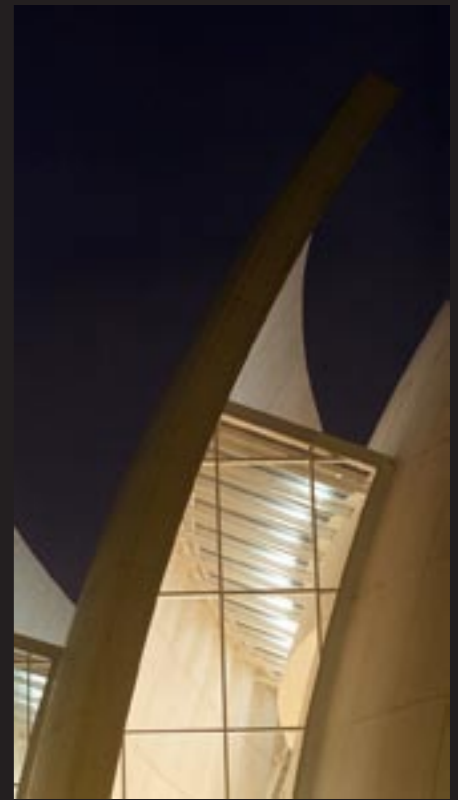

Designing vertical illuminance

The basics

Spatial effect

Vertical illuminance is a component of lighting design that is vitally important to architecture. Its primary purpose is to make spatial proportions and spatial limits visible. The opposite is the conventional horizontal illuminance, which is frequently the result of a purely functional, utilitarian and quantitative approach to design. In this latter case, the spatial experience is often secondary to the immediate visual task.

Vertical illuminance, however, can help complement the functional lighting design as well as become a starting point for architecturally orientated lighting concepts.

Illuminated walls give the observer a bright and open spatial impression. The fascination of wallwashing arises not only from the perception of brightness but also from the clear spatial presentation, which organises the architecture thereby making the surroundings more comprehensible.

From the point of view of perception psychology and aesthetics, wallwasher lighting is an important concept for constructing spaces with light. It is for this reason that it belongs to the essential repertoire of qualitative lighting design.



The functional advantages of wall illuminance are especially apparent when it comes to museum lighting. Appropriate illumination puts the artwork in the right light.

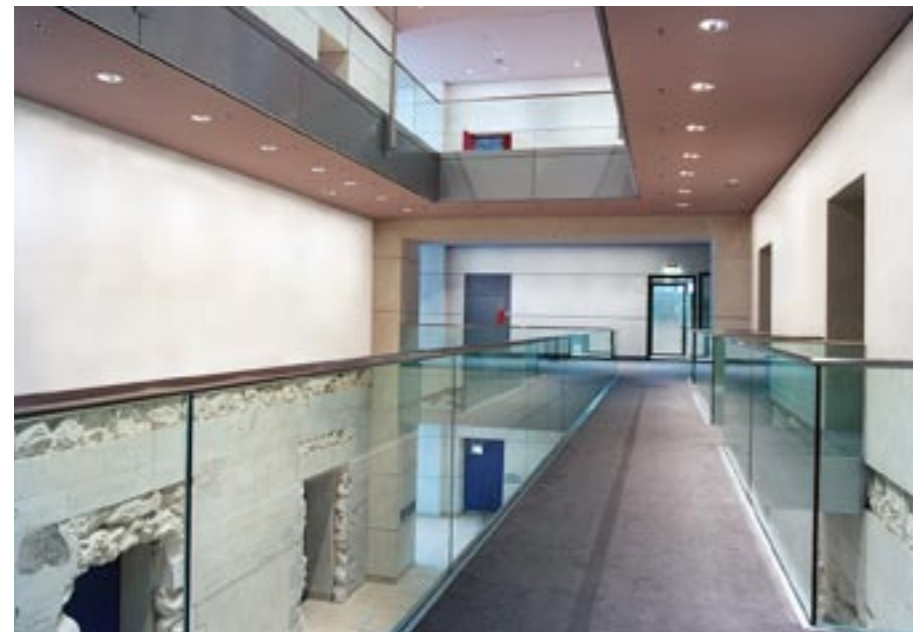

Through uniform wallwashing a clear spatial presentation occurs, which makes the architecture more legible and creates a bright spatial impression.



The uniform light distribution from the ceiling to the floor emphasises the wall as a whole and gives a wide spatial impression.

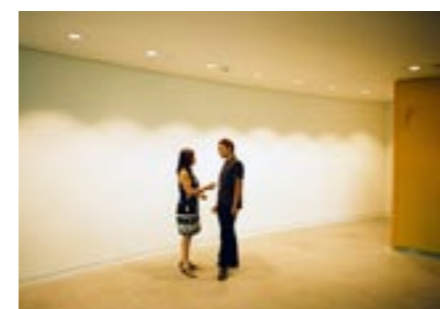

Light from point sources produces a scalloped pattern on the wall. These are not perceived as beams of light but as patterns in their own right.



Grazing light right next to the wall is an excellent way of bringing out the surface texture of materials using the interplay of light and shadow.

Lighting Options for Walls

Three different approaches to vertical illuminance give the lighting designer considerable artistic freedom for a differentiated approach to the lighting of walls. Of particular interest from the architectonic point of view is the practice of uniform wallwashing. An even light distribution from the ceiling to the floor emphasises the surface of the whole wall as a single unit. This approach achieves a bright spatial impression and brings the wall to the fore in its function as a delineating surface.

A second approach is to use grazing light up against the wall, the brightness distribution decreases across the wall. This type of lighting in particular brings out the material nature and texture of the wall surfaces. Point-source luminaires generate brilliant lighting effects. Conversely, linear sources produce a soft and diffuse effect.

The third method of illuminating walls is from point sources. The regular sequence of beam intersections or "scallops" forms a pattern and lends the wall surface a rhythm of brightness contrasts.

Special lighting tools are available for each of the different wallwashing techniques. Uniform wallwashing places the highest demands on the lighting technology. Various designs of wallwasher are available for this area of architecture.

Designing vertical illuminance

Internal areas



Wallwashing aids orientation in entrance areas: visitors understand the structure of a room faster and assimilate important information quicker. Particular details on walls such as inscriptions become even more noticeable.



Regardless of whether it is large-format advertising surfaces or walls with artworks in museums that are to be illuminated – uniform, vertical illuminance is an effective concept to illuminate walls and objects.



The combination of wallwashers and spotlights allows the general lighting to be supplemented by accent lighting.

It is not only the architectural design task that falls to vertical lighting in the indoor area but also that of a contribution towards perception. The classic visual tasks include recognising the environment and reading information on walls. The latter ranges from text information for orientation, paintings in galleries and museums through to merchandise in the world of shopping.

Uniform wallwashing holds great artistic potential: the wall itself can only be emphasised with its spatial and material quality or used as a neutral background for wall-mounted objects. The practice of reflecting light off walls produces a diffuse component of light in the room and this can be used as ambient lighting.

In particular, the areas of exhibitions and retail, whose pictures or merchandise are changed frequently, require a flexible lighting concept for walls. Uniform wallwashing offers a technique for the illumination of objects which does not require the luminaires to be constantly re-aimed to cater for rotating exhibits. It can also provide excellent presentation lighting. In the retail area, uniform wallwashing ensures that displays above the shelves are adequately illuminated.

Special wallwashers are suitable for large-format, full-height, advertising information because they bring the advertisement's entire surface to bear evenly and, by using high illuminance levels, are excellent for attracting attention.



Wall lighting in the daytime reduces the contrast of bright facades and room walls. At night, the even lighting of wall areas ensures a bright spatial impression is maintained.

Luminaires installed directly against the wall do not achieve uniform brightness from top to bottom. The linear grazing light of fluorescent lamps produces a diffuse light on the wall and creates a clear definition at the edge of the room where the wall meets the ceiling.



Although the use of horizontal workplace lighting is widespread in the office and administrative area, wallwashing can make a valuable contribution to the users' wellbeing in this area. Because the luminance influences the impression of brightness in the viewer's field of vision, the lighting of walls takes on an important role especially in small offices. This not only concerns having sufficient illuminance for visual tasks in places such as shelves or cabinets, but also the lighting of walls and graphic art, which makes the workplace environment appear more attractive. In addition, wall lighting also has a positive effect on luminance contrasts in the room: a higher background luminance reduces the contrast of both computer screens and luminaires. People's faces are also given an even and balanced modelling due to the higher component of diffuse light in the room.

In conference rooms and in large classrooms and auditoriums, sufficient vertical illuminance is particularly important for vertical presentation surfaces, enabling information to be read at a distance.

Designing vertical illuminance

External areas

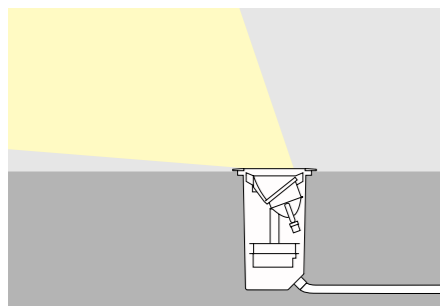

The lens wallwasher's asymmetrical light distribution is ideally suited to facade lighting. The light distribution avoids spill light straying upwards, enabling "Dark Sky" lighting solutions to be implemented.

Nocturnal facade lighting presents cities, local authority districts and private clients with a multitude of design possibilities for lighting both individual buildings as well as groups of buildings in the context of public squares, courtyards or main roads. The spectrum ranges from simple lighting intended primarily to provide orientation and safety, through to presentational lighting solutions and scenic illumination for special occasions. For buildings that are visible from afar, such as skyscrapers or towers, vertical lighting has the important task of highlighting nocturnal landmarks. Where buildings around the edge of public squares are concerned, facade lighting helps to ensure that these buildings are recognisable after dark and promotes better spatial understanding.

In the interest of a "Dark Sky", the lighting designer can effectively avoid what is known as light pollution (i.e. light which is emitted directly into the night sky) by using high-quality lighting technology and by arranging the luminaries appropriately.



The wall lighting in the indoor area is continued outside: the grazing lighting on the wall and the illuminated wall of trees both add to the emotive ambience on the terrace.



The texture of bas-reliefs on facades and of other material features can be enhanced by the shadow effect of wallwashing.



Many monuments and historical buildings tell their story in bas-reliefs, ornamentation or sculptural decoration. It is only with light and shadow that the three-dimensional nature and texture of the surfaces can be appreciated. Architectural details such as the constituency of materials, joints or facade patterns are also amongst those important features which, when discernable, will characterise the appearance of a building or structure at night.

The contrast on the surface can be influenced by the direction of the light and the type of luminaire. Moving a floodlight further away from the facade gives the surface a uniform but flat appearance because the formation of shadows is reduced. Conversely, luminaires positioned right next to the facade will produce extreme shadow, creating a dramatic impression. A mid-way position, as is the norm for wallwashers, gives a balanced appearance with an even light distribution on the surface, while still allowing the three-dimensional nature of any details to be easy to recognise.

Correction filters alter the colour impression for certain ranges of colour only. Thus, for instance, the warmer tone of the Skintone filter can emphasise the colour of beige sandstone. When using coloured light, a nocturnal perception and atmosphere is created which is distinct and independent from the daytime appearance. Certain moods and contrasts can be created with coloured light, and these can be used for instance to delineate large facade surfaces or to distinguish different parts of a building from each other.

Designing vertical illuminance

Internal and external areas – seen holistically

Vertical illuminance internally not only alters the atmosphere within a building but can also characterise the view of the building from the outside at night. When the indoor lighting is switched on with the onset of dusk, the reflection of the surroundings on transparent facades disappears. The facade gains spatial depth: the supporting structure appears as a contour and the people, furnishings and materials inside become more apparent.

It is important for entrance areas and foyers to have a striking night-time appearance which is effective even when seen from a distance.

This not only improves orientation but the wall lighting also guides the visitors to the building and conveys a prestigious and open spatial impression. An illuminance level higher than the surroundings or light of a different colour can emphasise such entrance areas when viewed from inside the building and make them stand out when viewing the facade.

Shop window lighting in particular utilises the advantages of vertical illuminance in several ways, including that of using a bright background to attract the attention of the consumers within the cityscape.



The internal wallwashing is visible from outside. Combined with transparent facades, the flowing transition from outside to inside gives great spatial depth.



To give a holistic appearance to the spatial concept, the uniform wallwashing inside the building is continued externally. Whatever the time of day, vertical lighting will ensure the wall remains the dominant feature of the internal space.

A different perspective is brought to bear when looking from the inside out. In the daylight, high contrasts occur in rooms between the high luminances in the window area and the opposite facing walls. In deep rooms that have low ceilings, this can give rise to a dark impression. In this case, lighting the walls will help to create a balance between the light and dark areas. Although, as a supplement to the daylight, it might not do much to aid vision at the workplace, it does considerably improve the way the room is perceived.

At night, windows appear as dark surfaces from the inside and the perspective seems to end where the indoor area ends. The task of extending spatial perception beyond the window falls to the outdoor lighting, and is achieved by illuminating architectural features in the outdoor area. The role of an illuminated outdoor wall in creating a single, holistic spatial composition combining indoor and outdoor areas can also be performed by illuminating vegetation. Reducing the lighting level internally will improve the view of the outdoor world, because there will be less reflections on the window surface.



Designing vertical illuminance

Colour and scenography

In architectural lighting, different light colours ranging from warm white and neutral white through to daylight white are used to differentiate spatial areas or to produce a different lighting atmosphere by day and by night. Styling with coloured light has a more intensive effect than white light. The bandwidth of colours ranges from pastel-shades through to strong primary and secondary colours. Coloured lighting can be used to give rooms and spaces dramatic scenic light and make them more eye-catching.

White walls provide a neutral background capable of transmitting every nuanced hue of the light colour. The impression of a coloured wall can be further strengthened using coloured light of the same colour, lending the room or area an impressive colour intensity.

One way of creating coloured light is to use colour filters mounted on the luminaires. Much more flexible in terms of scenographic light, however, are light sources that can dynamically change their colour. The principle behind this is the additive colour mixing of separately controllable light sources in the colours red, green and blue (RGB technology), e.g. using coloured fluorescent lamps or LEDs. In the ERCO product range, those luminaires that feature this colour mixing technology are designated "Varychrome" – such as the Varychrome Focalflood floodlight luminaires for fluorescent lamps. A lighting control system that controls the dimmer settings of the individual colour light sources and, in so doing, makes specific colours of light reproducible and integrates them in useful lighting scenes and sequences is indispensable for the effective use of Varychrome luminaires or other installations with RGB technology.



The colour contrast of cold and warm hues gives a festival in the ruins a most attractive setting. Many luminaires allow the light colour to be changed using colour filters.



The intensity of coloured surfaces can be significantly increased with coloured light of the same hue and can produce an impressive atmosphere.

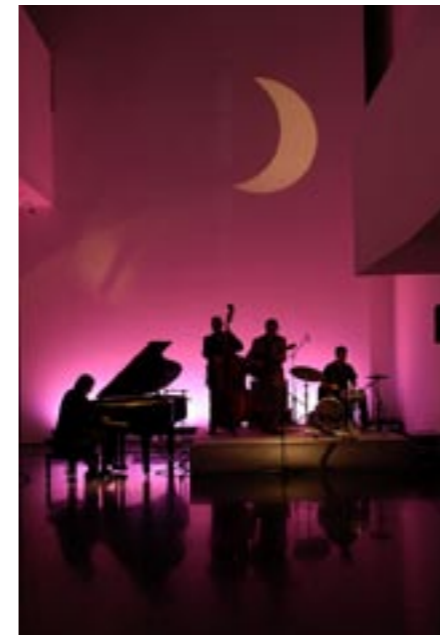

The possibilities of styling rooms with light are almost unlimited. One of the most fascinating properties of light is its ability to continually reinterpret architecture. Staging and controlling such metamorphoses with the inclusion of the time dimension is what we refer to as "scenographic light". By using innovative lighting tools for internal and external environments and systems for intelligently linking the luminaires, light can be formed into a coherent scenography in terms of its interaction with space, time and atmosphere. Scenographic light enormously increases the ability to experience quality in architecture, it magically attracts attention (as a concept for shop window lighting for instance) and it interprets the themes and concepts of exhibitions and events. With the help of ERCO lighting control systems, lighting scenes can be simply programmed and controlled at the touch of a button, be linked to particular sequences or simply loop.

Whereas a slow colour change subtly alters the atmosphere in the room or area, a faster scene change attracts more attention. Walls transformed with colour act as a backdrop, allowing the foreground to become a stage for dynamic effects.



An intuitive, graphic user interface opens up the multitude of functions for scenographic lighting. The right light for any situation can be set at the touch of a button.



Lighting tools

Internal areas: wallwashers for track and light structures

To produce the appropriate vertical illuminance for a given situation, different types of wallwashers are available. A classification for the wallwashers can be derived from the light distribution, the luminaire shape and its mounting. Point-sources such as recessed ceiling wallwashers are at the opposite end of the scale from linear luminaires, and there are also different-size versions for different lamps.

Wallwashers always produce an asymmetric light distribution in order to create uniform light on vertical surfaces. Depending on their design, they may also illuminate an area of the floor as well. Permanently installed wallwashers are offered in recessed and surface-mounted versions for the ceiling or the floor. In addition, wallwashers are also available as adjustable luminaires for track mounting. The entire spectrum of lamps are available as light sources: low-voltage halogen lamps, tungsten halogen lamps, PAR lamps and fluorescent lamps, plus the powerful high-pressure discharge lamps for high illuminance levels especially suitable for high walls.



Wallwasher spotlights

Track-mounted wallwashers are used for temporary or permanent illumination of vertical surfaces. Their aim can be adjusted to suit different wall heights and offsets from the wall.

A spread lens distributes the emitted light in the same way as a lens wallwasher. An additional reflector on the wallwasher attachment brightens the top of the wall nearest to the ceiling. The point-source lamps produce high brilliance.

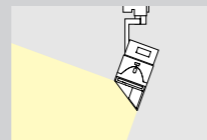

From left to right: Parscan, Eclipse, Quinta, Pollux, Optec, Stella

Jilly floodlights

Jilly floodlights provide a wide, axially symmetrical light distribution with the focal emphasis in the beam direction. The focal emphasis creates a bright, horizontal band on the wall, the position of which can be altered by tilting the floodlight. The deep reflector has a cut-off angle of 50° to provide a high degree of visual comfort.

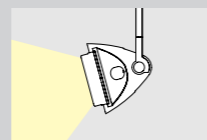
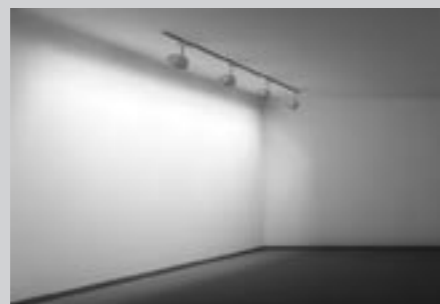

Jilly floodlight



Optec wallwashers

The triangular Optec wallwashers are not to be tilted, characteristic of these wallwashers is a light distribution where the light is directed both onto the vertical services and into the area of the room near to the wall. The linear Optec wallwashers for fluorescent lamps produce a diffuse light. Louvres improve the visual comfort when viewed acutely.

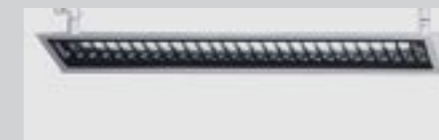
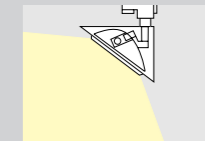

Optec wallwashers for fluorescent lamps



Optec wallwashers for low-voltage halogen lamps and tungsten halogen lamps

Monopoll wallwashers

Due to its design, this wallwasher belongs to the category of linear luminaires. Both the reflector technology and the properties of the fluorescent lamps ensure the wall is uniformly brightened. The fluorescent lamps of the linear wallwashers generate a low brilliance on the walls. The light distribution on the wall also extends above the suspended profile. The suspension and the profile, which is rotatable in 15° intervals, allow the light structure to be adjusted to suit the situation on site.

The modular construction of the light structures also allows the system to be continued for accentuation or general lighting in the central area of the room.

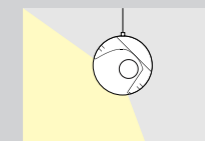
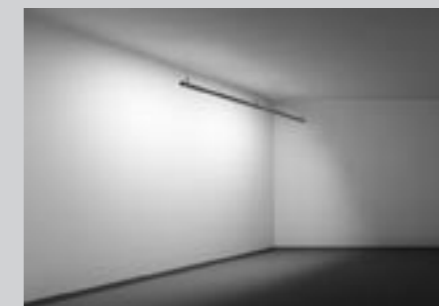

Monopoll wallwasher



Lighting tools

Internal areas: recessed luminaires

With wallwashers for recessed ceiling mounting, it is their lighting effect that is important. The luminaires themselves integrate so completely in the architecture that they barely register as an additional design feature.

The light apertures have a round, square or rectangular form. Depending on the type, the recessed luminaires can be installed with a frame for standard mounting, as a flush-mounted trim detail or with a shadow gap.

Lightcast recessed luminaires feature aluminium housings that have been thermally designed to meet the relevant technical requirements. The following lamps are used in recessed luminaires: low-voltage halogen lamps, tungsten halogen lamps, PAR lamps, metal halide lamps and fluorescent lamps.



Washlights

A characteristic of washlights is a light distribution in which the light is directed both vertically downwards and directly onto the vertical surfaces. Washlights feature an additional wallwasher reflector for the vertical component of the light.

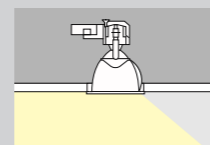

Lightcast washlight

Double washlights

Double washlights are offered for use in hallways, to enable the parallel walls as well as the floor area to be evenly illuminated. The light is re-directed by the double reflector.

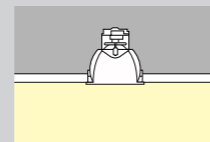

Lightcast double washlight

Double-focus wallwashers

This type of wallwasher achieves particularly good uniformity for the vertical illuminance distribution via a special wallwasher reflector. At the same time, the total cut-off of the lamp ensures exceptional visual comfort. The smaller light aperture in comparison to the lens wallwasher means that the luminaire appears less conspicuous in the ceiling. The room zones away from the walls remain un-illuminated.

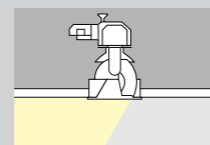
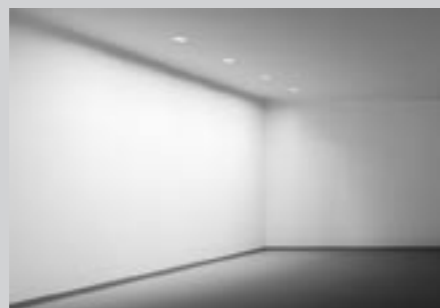

Lightcast double-focus wallwasher

Lens wallwashers

A sculpture lens spreads the beam out with the lens wallwasher and illuminates the wall very evenly. The lighting technology is efficient and a Darklight reflector ensures good visual comfort. Zones of the room away from the wall are not illuminated.

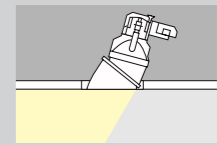
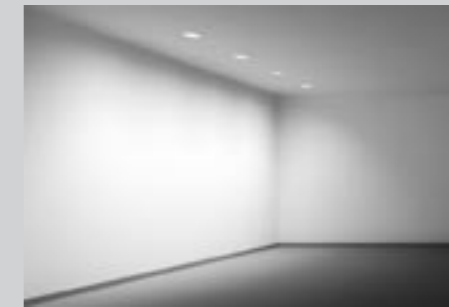

Lightcast lens wallwasher



Skim lens wallwasher



Quadra lens wallwasher

Wallwashers

The reflector geometry produces the necessary vertical illuminance for wall and shelf lighting. Typical for these wallwashers is a light distribution in which the light is directed both onto the adjacent vertical surface and downwards. Wallwashers for high-pressure discharge lamps and compact fluorescent lamps are available which are ideal for shelf lighting in sales areas.

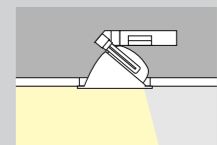
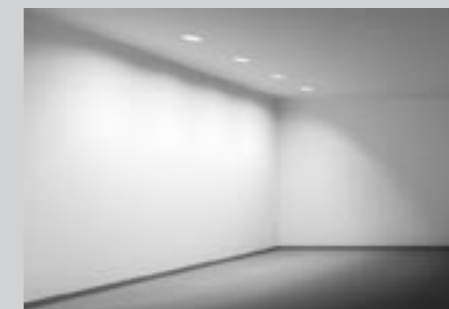

Lightcast wallwasher

Fluorescent wallwashers

Due to its design, this type belongs to the category of linear luminaires. Both the reflector technology and the properties of the fluorescent lamps ensure the wall is evenly illuminated. The linear wallwashers generate a low brilliance on the walls. The diffuse light results in very good uniformity.

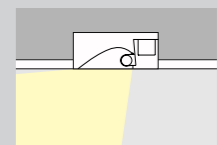
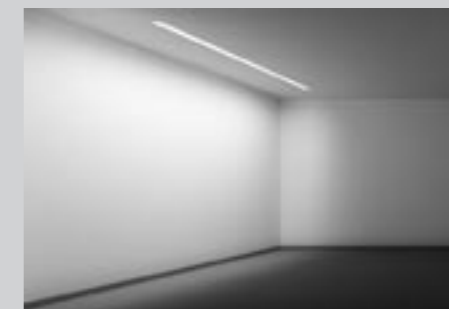

Fluorescent wallwasher

Lighting tools

External areas: floodlights and wallwashers

Designers require lighting instruments for the outdoor areas which are engineered to the same high lighting precision as ERCO's indoor range. ERCO's extensive experience in the development of luminaires with asymmetric light distribution has been transferred to the wallwashers of the outdoor product range, resulting in high-quality lighting solutions with very good uniformity and optimum glare control. Construction and design are rigorously orientated for external application.

Low-voltage halogen lamps, tungsten halogen lamps, PAR lamps, metal halide lamps and fluorescent lamps are all available for outdoor luminaires.



Focalflood floodlights

Focalflood floodlights provide a wide, axially symmetrical light distribution with focal emphasis and are therefore excellently suited to lighting objects on walls. The focal emphasis creates a bright, horizontal band on the wall. The floodlight produces very good visual comfort with a cut-off angle of 50°.

Using additive colour mixing (RGB technology), Focalflood varychrome luminaires can create light in a multitude of different hues. A diffuser and a Softec lens ensure the three primary colours are thoroughly mixed.



Focalflood floodlight

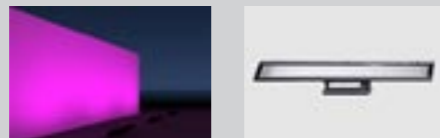

Focalflood varychrome floodlight for fluorescent lamps

Parscoop wallwashers and washlights

The reflector geometry produces an asymmetric light distribution and achieves an even illumination on surfaces. The washlights emit their maximum illuminance distribution at below approx. 20° providing optimum uniformity. Parscoop luminaires can be mounted on ceilings, walls or floors and are also tiltable.

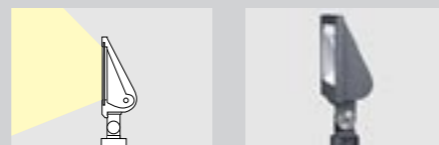

Parscoop wallwasher and washlight

Lightmark facade washlights

Lightmark facade washlights produce a wide and very uniform illumination of vertical surfaces due to their asymmetric reflectors. The version designed as a bollard luminaire allows the light aperture to rise above the surrounding vegetation.



Lightmark facade washlight

Lightcast directional luminaires

The directional luminaires contain a sculpture lens. This combination results in a light distribution similar to that of a lens wallwasher. The lighting technology is very efficient and the Darklight reflector ensures good visual comfort.



Lightcast directional luminaire

Paratec wallwashers

The reflector geometry produces an asymmetrical light distribution and results in a very uniform illumination on vertical surfaces. The luminaire protrudes out of the ceiling to provide an even illumination of the upper wall, all the way up to the ceiling.



Paratec wallwasher

Tesis lens wallwashers

With Tesis lens wallwashers, a sculpture lens spreads the beam out and illuminates the wall very evenly. The lighting technology is very efficient and the Darklight reflector ensures good visual comfort. The light distribution is directed solely at the walls. This avoids any upward spill light into the night sky.



Tesis lens wallwasher

Lightmark facade luminaires

Lightmark facade luminaires produce a wide, grazing light on the facade. The axis of the light aperture is slightly tilted towards the facade to avoid any unnecessary spill light straying into the night sky. An optional mounting frame increases the offset to the wall to improve the area and uniformity of the illuminated facade surface.

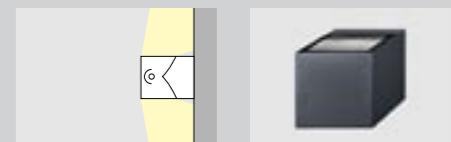

Lightmark facade luminaire

Design and planning in practice

Luminaire selection and arrangement

Criteria for wallwashers

The most important criteria for wallwashers are the uniformity of the wall's illuminance, the uniformity of the luminance gradient on the wall and the luminaire cut-off. The illuminance in the vertical plane should be as even as possible. The prerequisite for an even illuminance on the wall is an asymmetric light distribution which is adjusted to suit the geometric relationship between the vertical surface and the luminaire position. The beam's side edges fade out softly in order to give good horizontal uniformity. A symmetric light distribution with a ceiling mounted set-up would cause a dark patch on the wall area near the ceiling and would also reduce the economic efficiency since the light is not just shining on the vertical usable area alone.

An effective cut-off angle for recessed ceiling luminaires improves visual comfort. The eye will not be dazzled as long as the lamp remains within the reflector's cut-off angle. To additionally prevent any glaring reflections from arising in the reflector, its geometry has to be calculated such that no high luminance levels are found within the cut-off angle. If higher visual comfort is required – such as a total shielding of the lamp from below – then further shielding measures will be required. The demands for visual comfort and economic efficiency must be weighed up in each individual case.

Light colour, colour rendition and brilliance particularly influence the choice of lamp for wallwashers. Linear wallwashers with fluorescent lamps appear to give less brilliance on the wall than point-source lamps. However, their diffuse light gives a more gentle modulation on the wall and produces a very uniform impression of brightness.

Adding emphasis to vertical surfaces has a positive effect on the visual comfort in two respects: firstly, the principle arrangement of the luminaires near to the wall means that they are largely removed from the observer's visual field, and in many cases direct glare is avoided from the start. Secondly, brightening the room surfaces causes a reduction in the contrast between the light sources and the background. The subjective glare caused by looking into the luminaire is therefore perceived to be less intensive or less irritating. The so-called UGR value or Unified Glare Ratio – a value that can be calculated to quantify the glare from a specific point in a room is better than for a room with poorly illuminated walls.

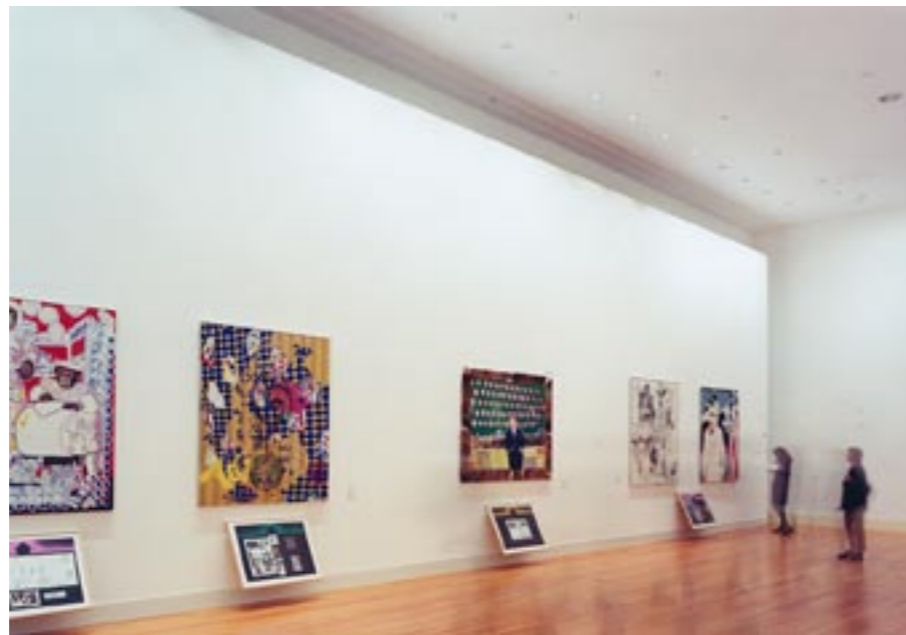

The double-focus wallwashers achieve an excellent uniformity on the wall due to the design of their reflectors. By completely concealing the lamp using an anti-dazzle cone the design simultaneously ensures exceptional visual comfort.

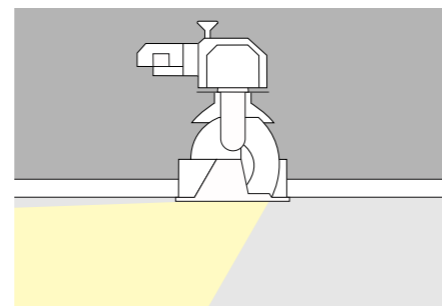

Low-voltage halogen capsule lamps and tungsten halogen lamps provide brilliant light and, thanks to their continuous spectrum, perfect colour rendition.



Parabolic aluminised reflector lamps and halogen parabolic reflector lamps are renowned for their brilliant light and very good colour rendition. The parabolic reflector makes the first contribution to harnessing the beam.



Modern metal halide lamps with ceramic discharge tubes combine brilliant light and extreme luminous efficacy with good colour stability and colour rendition.

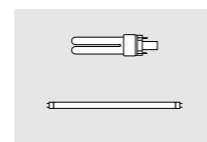

Compact and linear fluorescent lamps are ideal for diffuse and economical wall lighting.

Arranging wallwashers

A few guidelines will help the designer position wallwashers correctly, thereby achieving a very even light on the wall: the offset of the luminaire from the wall should be one third of the room height. Alternatively, the offset from the wall can be found by extending a 20° line from the base of the wall up to the ceiling. A lower offset from the wall will give a bright patch of light (hotspot) just in front of the luminaire, this will impair the vertical uniformity on the wall. Furthermore, with lens wallwashers, the light distribution will then no longer reach the base of the wall. Additionally, the texture of the surface will appear less soft because the increased component of grazing light will cause a greater degree of shadow.

An optimum horizontal uniformity is achieved when the luminaire spacing is equal to the offset from the wall. A greater separation between the luminaires would cause dark stripes between the luminaire centre lines and thus impair the uniformity of the wallwashing. To compensate for reduced illuminance levels in high rooms, either the luminaire spacing has to be decreased or a higher lamp power has to be used.

Wallwashers do not develop their maximum uniformity until at least three luminaires are used. Therefore when viewing mock-ups at least three luminaires must be supplied for a meaningful appraisal.

Whereas in the indoor area the preferred location for the luminaires is in the ceiling, for the outdoor area recessed floor luminaires with a protection mode appropriate to their mounting location are available. The guidelines for wallwashing in the indoor area can be transferred to facade washlighting in the outdoor area. The use of surface-mounted luminaires on bollards or upright supporting poles has an advantage over recessed floor luminaires in that the luminaires do not become overgrown by vegetation.

On the basis of a "Dark Sky" lighting design that avoids light pollution, washlights with asymmetric light distribution are more suitable for vertical lighting in the outdoor area than those with symmetrical light distribution. This is because, with the latter, the part of their beam that is not directed at the wall produces spill light. This wastes energy and causes light pollution in the atmosphere.

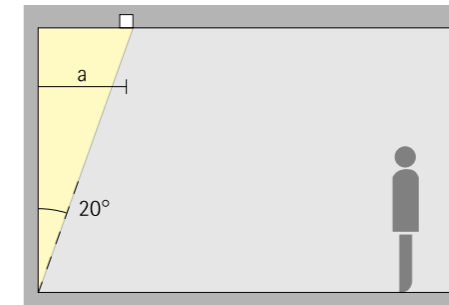

To achieve an even light distribution on the wall, the offset (a) of the luminaire from the wall should be at least one third of the room height.

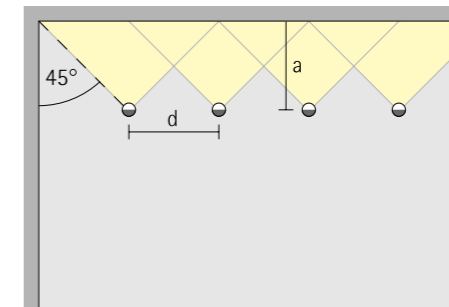

A wallwasher in a room corner should be positioned on the 45° line between the two walls. The brightness can then fade unnoticeably towards the corner and can also remain inconspicuous on the side wall.

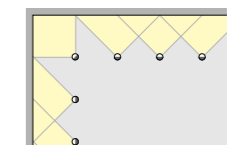
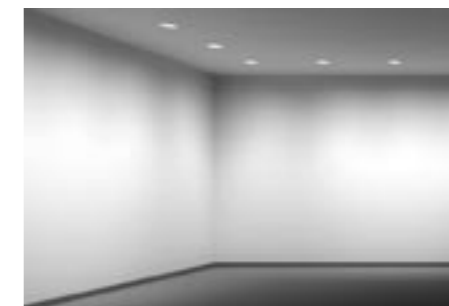

When continuing the wall lighting around the room corner, one wallwasher can be aimed at the corner.

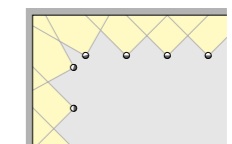
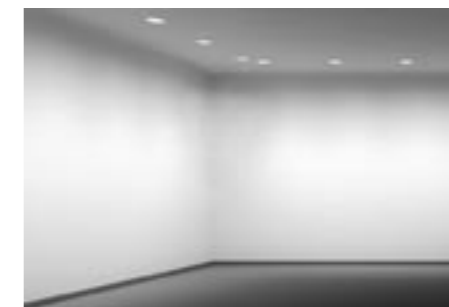

The side striation produced by the above-mentioned arrangement can be avoided by having a double wallwasher arrangement in the corner.

Design and planning in practice

Luminaire selection and arrangement

Integrated and additive lighting solutions

When selecting the type of mounting, aesthetic aspects are often important. Wallwashing can be designed as an architecturally integrated or additive lighting solution. With recessed luminaires, it is their lighting effect that comes to the fore while the luminaires themselves remain largely hidden from the view of the observer. Conversely, with the additive approach of surface-mounted luminaires, the focus is more on the luminaire itself. Furthermore, track-mounted luminaires also feature added flexibility. The important thing when it comes to the design is to consider the unity of shapes and forms between lighting and architecture.

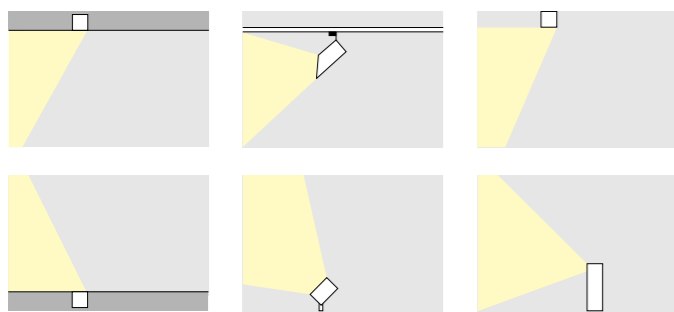

Wallwashers can be installed on the ceiling or on the ground, and are offered in both recessed and surface-mounted versions.

With track-mounted wallwashers, the luminaire spacing and the illuminance can also be subsequently changed.



The ERCO Program catalogue and the product data sheets give helpful design tips for each wallwasher. The mean illuminances are available for different wall offsets and luminaire spacings for calculation purposes. As an example here is the calculation table for the Optec wallwasher 77758.000.

Mean illuminances E_m (lx)

Based on:
 Number of luminaires $n > 5$
 Light loss factor 1.25
 Without indirect component
 Without peripheral area

Room height (m)	3.00			
Offset from wall (m)	1.00	1.00	1.25	1.25
Luminaire spacing (m)	1.00	1.25	1.25	1.50
Illuminance (lx)	263	215	178	150

Surfaces

Wallwashing emphasises the texture of high quality, specifically selected wall surfaces such as wood, natural stone, textiles or even bare concrete. The prerequisite for an even wall washing is to have pale and matt surfaces. The diffuse reflection on such walls also gives the room or area a soft, indirect general lighting. Conversely, dark wall colours reduce the impression of brightness in the room or area and require quite high illuminance levels to compensate for this. Caution is required with shiny wall surfaces having high reflectance, such as polished stone or metal – the wallwashing can cause an unpleasant reflection of the light sources. Stark luminance contrasts particularly arise with dark, shiny walls due to bright light sources.

The colour of walls can be impressively increased by additional lighting with the appropriate colour filters. Where recessed floor luminaires are used in front of textured walls, the effect of shadows, which is opposed to the natural daylight and the general lighting, needs to be considered.



Wallwashing reveals the texture of rough surfaces.



Guide values for illuminance levels

For museum lighting, an illuminance of 50 lx can be taken as a guide value for sensitive exhibits and 200 lx for less sensitive artefacts. On shelves in libraries 200 lx is recommended as a guide value, whereas 175 lx will suffice for shelf lighting in offices. Writing boards in school halls, lecture rooms and auditoriums require 500 lx.

For outdoor lighting at night, as little as 10 lx is sufficient as the vertical illuminance in a dark environment. To create a link between outdoor and indoor areas at night, approximately 100 lx is required on a foyer wall to give a bright spatial impression.



Experience light – globally

ERCO showrooms and offices



ERCO sees itself as a cosmopolitan, globally active company. ERCO showrooms and offices are found in all important markets. Here our well-trained, highly specialised employees are available for consultation. Especially on international projects, this worldwide network ensures consistent, reliable, local service and competent, local customer care: from advice at the design phase, tendering, provision of samples and project planning through to customer service and training.

A "consultant to the consultant" – is how the ERCO lighting specialists might see their role in the building process: they provide professional support for designers and planners on all lighting technology issues and in all phases of the project. By providing case-related, technical information and comprehensive project documentation, they help the decision-making process so that the right lighting tools are selected.

The showrooms and offices provide the optimal premises for meetings at all the phases of the project. A mock-up area is available for sample and product demonstrations.

But the ERCO service does not end with the punctual delivery of the requested article: the lighting specialists are available to assist in word and deed when the system is in operation.



The large number of luminaire groups which are mounted ready for operation and are addressable by a lighting control enables a direct comparison between products such as ceiling integrated lens wallwashers (above) and track-mounted Optec wallwashers (left).

tion. This service may consist of advice on replacing the lamps or a helping hand when focusing the luminaires.

All addresses can be found at: www.erco.com/contact



Experience the effect of perfect wallwashing: the showrooms, like the one here at ERCO London, provide the necessary infrastructure.



The striking architecture of light demonstrates the company's claims and capabilities: the headquarters of ERCO Holland in Naarden.



The effect of light in space is difficult to express in words or images – it must be experienced. The ERCO showrooms provide optimum, flexible conditions for this task.



The offices provide ideal spaces for project meetings: conference at ERCO Dubai, UAE.

The lighting display obelisk – a recurrent feature in the show-room concept that allows lighting effects to be excellently demonstrated: this one is at ERCO Sweden in Stockholm.

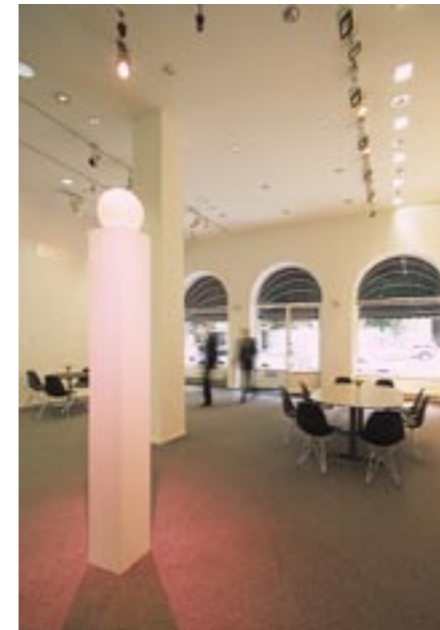

Events and seminars turn ERCO showrooms into meeting places for the local lighting and architectural milieu: for instance at ERCO Poland in Warsaw.



The provision of product samples is a typical service of the lighting consultants in the showrooms: the office of ERCO Japan in Tokyo.

Lighting preview

Virtual luminaires and simulation



Creative lighting concepts start in the mind. The journey from thought to reality takes time and can require considerable conviction. The task of implementing an architectural concept is largely a matter of communication.

Since spatial perception is primarily visual, computer-generated visualisations have gained a permanent place in the process of design. However, just like real architecture, virtual architecture only comes to life with light. That's why every ERCO luminaire has its own virtual "twin" in the form of digital luminaire data, which can be downloaded from the ERCO Light Scout website and inserted directly into a lighting simulation. Visualisation software creates dimensionally accurate studies, simulations and analyses – all in photorealistic quality. It is especially in the field of lighting vertical surfaces that simulation proves itself to be a valuable tool for authentically displaying the effect of wallwashers and avoiding planning errors.

The "virtual luminaires" are just part of the extensive information and documents available online in Light Scout. In addition there are images, symbols, specification text, data sheets, photometric data and much more – all with the aim of providing access to the latest information from any location and at any time during the design process.

The following information for each individual ERCO lighting tool is available for downloading from Light Scout (sometimes compressed as a .zip file): product data sheets (.pdf), article texts (.txt), product images (.jpg), photometric data in IES and Eulumdat formats, 3D-models for 3D-CAD (.dxf), i-droppable data for DIALux (.uld), and luminaire files for 3D Studio VIZ 3, Autodesk VIZ 4 (i-drop), Autodesk MAX (i-drop) and for Lightscape.

www.erco.com

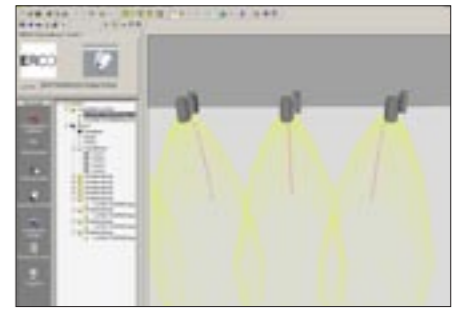

The free light calculation program, DIALux, provides comprehensive, user-friendly calculation and display possibilities for all who design with light (available from: www.dialux.de).

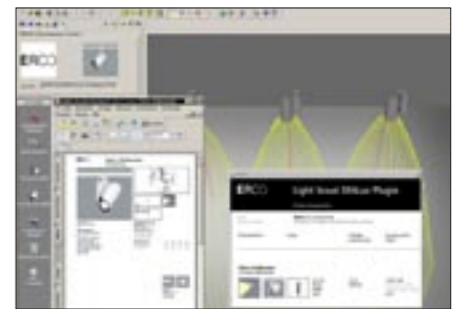

Whether from a CD-ROM or taken directly from the Internet as an "i-droppable" online plug-in, ERCO design data fits seamlessly into the digital design process with DIALux.



Light Scout is the name of ERCO's website. It links extensive product information with reference projects and the Guide. The latter provides the basics of lighting design and explains the optimum use of ERCO lighting tools.

ERCO addresses

Europe:

Austria

ERCO Leuchten GmbH
Zweigniederlassung Wien
Modecenter Str. 14/4.OG/BC
A-1030 Wien
Austria
Tel.: +43 1 798 8494 0
Fax: +43 1 798 8495
e-mail: info.at@erco.com

Belgium

ERCO Lighting Belgium Bvba/sprl
Leuvensesteenweg 369 bus 7
1932 Zaventem
Belgium
Tel.: +32 2 340 7220
Fax: +32 2 347 3882
e-mail: info.be@erco.com

Cyprus

J. N. Christofides Trading Ltd.
P.O. Box 21093
1c Kennedy Avenue
CY-1501, Nicosia
Cyprus
Tel.: +357 22 813 043
Fax: +357 22 813 046
e-mail: mail@jnc.com.cy

Czech Republic

ERCO Leuchten GmbH
Organizačni slozka
Jana Masaryka 3/456
120 00 Praha 2
Czech Republic
Tel.: +420 2 225 111 16
Fax: +420 2 225 217 12
e-mail: info.cz@erco.com

Slovakia

see Czech Republic

Denmark

ERCO Lighting
Vesterbrogade 136 C, st.
1620 København V
Denmark
Tel.: +45 332 180 060
Fax: +45 332 180 064
e-mail: info.dk@erco.com

Finland

Oy Hedtec Ab
Lauttasaarentie 50
FIN-00 200 Helsinki
Postilokero 110
FIN-00 201 Helsinki
Finland
Tel.: +358 9 682 881
Fax: +358 9 673 813
e-mail: lighting@hedtec.fi

France

ERCO Lumières Eurl
6ter, rue des Saints-Pères
F-75007 Paris
France

Groupe Paris-Ile de France
Tel.: +33 1 44 77 84 71
Fax: +33 1 47 03 96 68
Groupe Régions
Tel.: +33 1 44 77 84 75
Fax: +33 1 49 27 06 48

Groupe Architecture Commerciale
Tel.: +33 1 44 77 84 70
Fax: +33 1 44 77 84 84
e-mail: info.fr@erco.com

Germany

ERCO Leuchten GmbH
Postfach 2460
58505 Lüdenscheid
Brockhauser Weg 80–82
58507 Lüdenscheid
Germany
Tel.: +49 2351 551 100
Fax: +49 2351 551 603
e-mail: info.de@erco.com

Great Britain

ERCO Lighting Ltd.
38 Dover Street
London W1S 4NL
Great Britain
Tel.: +44 20 7408 0320
Fax: +44 20 7409 1530
e-mail: info.uk@erco.com

Greece

Expo Ltd.
Nimfeou Str. 20 Et 24
11528 Athens
Greece
Tel.: +30 210 748 5560
Fax: +30 210 770 6342
e-mail: Expo@compulink.gr

Hungary

ERCO Fénytechnika
ERCO Leuchten GmbH
Kereskedelmi Képviselet
Budapest
Irányi u. 1. mfsz. 2.
H-1056
Hungary
Tel.: +36 1 266 0006
Fax: +36 1 266 0006
e-mail: info.hu@erco.com

Ireland

Designlight Ireland Ltd.
289 Harolds Cross Road
Dublin 6W
Ireland
Tel.: +353 1 496 6177
Fax: +353 1 496 6851
e-mail: info@erco.ie

Italy

ERCO Illuminazione S.r.l.
Via Vivaldi
Residenza dell' Orione 34
20080 Basiglio (Milano)
Italy
Tel.: +39 02 904 5031
Fax: +39 02 904 503 51/42
e-mail: info.it@erco.com

Netherlands

ERCO Lighting Nederland B.V.
Gooimeer 13
1411 DE Naarden
Netherlands
Tel.: +31 35 699 1710
Fax: +31 35 694 6383
e-mail: info.nl@erco.com

Norway

ERCO Belysning A.S.
Industriveien 8 B
N-1473 Lørenskog
Postboks 83 Ellingsrudåsen
N-1006 Oslo
Norway
Tel.: +47 67 973 240
Fax: +47 67 973 244
e-mail: info.no@erco.com

Poland

ERCO Leuchten GmbH. Sp. z o. o.
Przedstawicielstwo w Polsce
ul. Bialy Kamien 7
02-593 Warszawa
Poland
Tel.: +48 22 898 7845
Fax: +48 22 898 2939
e-mail: info.pl@erco.com

Portugal

Omnichel
Técnicas de Iluminação, S.A.
Rua Castilho, 57-5. Dto.
1250-068 Lisboa
Portugal
Tel.: +351 21 381 3080
Fax: +351 21 381 3090
e-mail: omnicel.lx@omnicel.pt

Spain

ERCO Iluminación, S.A.
c/ El Plà nº 47
08750 Molins de Rei, Barcelona
Spain
Tel.: +34 93 680 1110
Fax: +34 93 680 0546
e-mail: info.es@erco.com

Delegación Cataluña
c/ El Plà nº 47
08750 Molins de Rei, Barcelona
Spain
Tel.: +34 93 680 1244
Fax: +34 93 680 2624
e-mail: info.barcelona@erco.com

Delegación Centro
c/ Buen Suceso nº 13
28008 Madrid
Spain
Tel.: +34 91 542 6954
Fax: +34 91 559 0965
e-mail: info.madrid@erco.com

Sweden

ERCO Lighting
Birger Jarlsgatan 46
11429 Stockholm
Sweden
Tel.: +46 8 545 044 30
Fax: +46 8 545 044 39
e-mail: info.se@erco.com

Switzerland

Neuco AG
Würzgrabenstrasse 5
CH-8048 Zürich
Switzerland
Tel.: +41 44 437 3737
Fax: +41 44 437 3738
e-mail: mail@neuco.ch

Neuco SA
100, route de Cossonay
CH-1008 Prilly
Switzerland
Tel.: +41 21 637 3000
Fax: +41 21 637 3003
e-mail: mail.prilly@neuco.ch

Turkey

Total Aydinlatma A.S.
Mesrutiyet Cad. 145-147
80050 Tepebasi/Istanbul
Turkey
Tel.: +90 212 251 9171 (pbx)
Fax: +90 212 251 9172
e-mail: info.tr@erco.com

The Middle East:

Dubai

ERCO Lighting
ERCO Leuchten GmbH
Representative Office Dubai
P.O. Box 62221
Dubai
United Arab Emirates
Tel.: +971 4 336 9798
Fax: +971 4 337 3746
e-mail: info.ae@erco.com

Egypt

Jordan

Kuwait

Oman

Qatar

see Dubai

Lebanon

La Giralda
Mme Curie Street
Beirut-Lebanon
P.O. Box 13-5554
Lebanon
Tel.: +961 1 864 641
Fax: +961 1 867 353
e-mail: lagirald@inco.com.lb

Saudi Arabia

Technolight
P.O. Box 12679
Jeddah 21483
Saudi Arabia
Tel.: +966 2 669 3241
Fax: +966 2 665 9664
e-mail: jeddahbranch@technolight-ksa.com

United Arab Emirates

Scientechnic
PO Box 325
Dubai
United Arab Emirates
Tel.: +971 4 266 6000
Fax: +971 4 266 6176

East Asia:

China

ERCO Lighting
ERCO Leuchten GmbH
Representative Office Shanghai
Rm 2015, Civil Aviation Center
18, Xin Jinqiao Road Pudong
Shanghai 201206
China
Tel.: +8621 5030 5979
Fax: +8621 5030 5879
E-Mail: info.cn@erco.com

Hong Kong

Architectural Lighting (HK) Ltd.
3/F. Shing Dao Industrial Building
232 Aberdeen Main Road
HK-Aberdeen, Hong Kong
P.O. Box 3 05 21, Causeway Bay
China
Tel.: +852 287 022 88
Fax: +852 255 227 87
e-mail: waal@williamartists.com

Japan

ERCO TOTO Ltd.
Shibakoen ND Bldg.
2-5-10 Shiba
Minato-ku
Tokyo 105-0014
Japan
Tel.: +81 3 5418 8230
Fax: +81 3 5418 8238
e-mail: info.jp@erco.com

Korea

Altek Lighting
Kyung-Nam Bldg. 2nd Floor
Sinsa-Dong, Kangnam-Gu
Seoul
Korea
Tel.: +82 2 512 7779
Fax: +82 2 512 4117
e-mail: altek@altek.co.kr

Malaysia

ERCO Lighting
ERCO Leuchten GmbH
Representative Office (K.L.)
Level 40, Tower 2
Petronas Twin Tower
Kuala Lumpur City Centre
50088 Kuala Lumpur
Malaysia
Tel.: +60 3 2168 4479
Fax: +60 3 2168 4201
e-mail: info.my@erco.com

Singapore

ERCO Leuchten GmbH
Representative Office (S.E.A.)
63A Club Street
Singapore 069437
Singapore
Tel.: +65 6 227 3768
Fax: +65 6 227 8768
e-mail: info.sg@erco.com

Brunei

Indonesia

Philippines

see Singapore

Thailand

Palicon Pro-Art Lighting Ltd.
58/3 Soi Prompak,
Sukhumvit Road
Klongton-Nua, Vadhana
Bangkok 10110
Thailand
Tel.: +662 382 1851
Fax: +662 382 1852
e-mail: uwe@ksc7.th.com

North America:

USA

ERCO Lighting Inc.
160 Raritan Center Parkway
Suite 10
Edison, NJ 08837
USA
Tel.: +1 732 225 8856
Fax: +1 732 225 8857
e-mail: info.us@erco.com

Canada

Mexico

see USA

South America:

Argentina

ERCO Leuchten GmbH
Oficina de Representación
Av. Alicia M. de Justo 2030, Of.202
1106 Buenos Aires
Argentina
Tel.: +54 11 431 314 00
Fax: +54 11 431 254 65
e-mail: info.ar@erco.com

Bolivia

Brazil

Chile

Colombia

Ecuador

Paraguay

Peru

Uruguay

Venezuela

see Argentina

Australia

ERCO Lighting
ERCO Leuchten GmbH
Representative Office Australia
349 Pacific Highway
North Sydney NSW 2060
Australia
Tel.: +61 2 9004 8801
Fax: +61 2 9004 8805
e-mail: info.au@erco.com

New Zealand

see Australia

ERCO head office

ERCO Leuchten GmbH
Postfach 2460
58505 Lüdenscheid
Brockhauser Weg 80–82
58507 Lüdenscheid
Germany

Tel.: +49 2351 551 0
Fax: +49 2351 551 300
e-mail: info@erco.com
Internet: www.erco.com

For the latest version of the
address list, please visit:
www.erco.com